



**HEWLAND**  
**ENGINEERING LIMITED**

**SERVICING INSTRUCTIONS AND ILLUSTRATED  
PARTS LIST FOR THE FTR FAMILY OF HEWLAND  
GEARBOXES, COVERING FTR, FTRS, FTRL, JFR &  
LJS UNITS.**

HEWLAND ENGINEERING LTD  
WALTHAM ROAD, WHITE WALTHAM,  
MAIDENHEAD, BERKSHIRE,  
SL6 3LR, ENGLAND  
TELEPHONE: +44 (0)1628 827600

Last Updated 2nd September 2011

© Copyright Hewland Engineering Limited 2001-2009

## **CONTENTS :-**

	<b>Page</b>
Technical Specification & Gear Selection	7
General Notes	8
Differential bearing preload & Crownwheel backlash setting	9
Pinion Setting	12
Sequential Fork Setting	13
Changing Gear Ratios	14
Powerflow Differential	15
FTR-212-ADJ Backlash adjustment	16
Gearbox assembly	18
FTR/JFR 6 Speed Illustrated Parts List	20
FTR/JFR 6 Speed (with FTREL Barrel) Illustrated Parts List	29
FTR/JFR 6 Speed conversion to 5 Speed	31
FTR 6 Speed (fitted with FTRE ratios) Illustrated Parts List	32
FTR/JFR 5 Speed Illustrated Parts List	40
FTRS 6 Speed Illustrated Parts List	49
Bearing Carrier Options	50
Differential Options Illustrated Parts List	51
Typical Ramp Orientation	66
Gaitor Assembly	67

## **CONTENTS :-**

	<b>Page</b>
FTRE and FTRL Lightweight Tripod Assemblies	68
Gearbox Tooling	69
Low Friction Bearing Tooling	71
Installation drawings	72
Pneumatic shift actuator installation	80
FTRL Hubbed 2nd Gears	81
Technical Bulletins	82
General K-Nut Tightening Torques	100
Manual Modification History	101

## ILLUSTRATIONS:-

	<b>Page</b>	
Fig. 1	Backlash Adjustment	10
Fig. 2	Differential Bearing Preload	11
Fig. 3	Pinion Shaft Setting	12
Fig. 4	Sequential Barrel Setting	13
Fig. 5	Powerflow Diff Assembly	15
Fig. 6	FTR-212-ADJ Assembly	16
Fig. 7	FTR-212-ADJ Tooling	17
Fig. 8	Casing & Associated Parts - 6 Speed (not FTRE ratios)	21
Fig. 9	Layshaft Assembly - 6 Speed (not FTRE ratios)	22
Fig. 10	Pinion Shaft Assembly - 6 Speed (not FTRE ratios)	23
Fig. 11	Selector Assembly - 6 Speed (not FTRE ratios)	24
Fig.12	Selector Assembly –6 Speed (FTREL Barrel only)	29
Fig.13	5 Speed Conversion Assembly - 6 Speed Gearbox	31
Fig.14	Casing & Associated Parts - 6 Speed (FTRE ratios)	33
Fig.15	Layshaft Assembly - 6 Speed (FTRE ratios)	34
Fig.16	Pinion Shaft Assembly - 6 Speed (FTRE ratios)	35
Fig.17	Selector Assembly - 6 Speed (FTRE ratios)	36
Fig.18	Casing & Associated Parts - 5 Speed (not FTRE ratios)	41
Fig.19	Layshaft Assembly - 5 Speed (not FTRE ratios)	42
Fig.20	Pinion Shaft Assembly - 5 Speed (not FTRE ratios)	43
Fig.21	Selector Assembly - 5 Speed (not FTRE ratios)	44
Fig.22	FTRS Additional Parts	49

## ILLUSTRATIONS :- continued

	<b>Page</b>	
Fig.23	Bearing Carrier Options	50
Fig.24	Tripod Differential Assembly	52
Fig.25	FTR-212-FD	53
Fig.26	FTR-212	54
Fig.27	FTRL-212	55
Fig.28	Tripod Adjustable Differential Assembly	56
Fig.29	FTR-212-ADJ	57
Fig.30	Flanged Free Differential	58
Fig.31	LJS-212-F	59
Fig 32	LD-212	60
Fig 33	LD-212-CP	61
Fig.34	Flanged Free Differential Inboard Brake Discs	62
Fig.35	LJS-212-F	63
Fig.36	Flanged LSD Differential Inboard Brake Discs	64
Fig.37	LD-212	65
Fig.38	Ramp Orientation	66
Fig.39	Gaitor Assembly	67
Fig.40	FTRE and FTRL Lightweight Tripod Assemblies	68
Fig.41	Gearbox Tooling	69
Fig.42	Low Friction Bearing Tooling	71
Fig.43	Installation Drawing - FTR	73
Fig.44	Installation Drawing - JFR	74
Fig.45	Installation Drawing - Bearing Carriers	75

## ILLUSTRATIONS :- continued

	<b>Page</b>
Fig.46a-c Installation Drawing - Flanges	76-79
Fig.47 FTRL Hubbed Gears	81
Fig.48 Technical Bulletin - 01A	84
Fig.49 Technical Bulletin - 02	85
Fig.50 Technical Bulletin - 02	86
Fig.51 Technical Bulletin - 08	92
Fig.52 Technical Bulletin - 013	96
Fig.53 Technical Bulletin - 014	97
Fig.54 Technical Bulletin - 040	99

## TECHNICAL SPECIFICATION

The FTR gearbox family are transaxle units, designed for mid-engined, rear wheel drive cars. The units are produced with six or five forward gears, reverse, and a differential.

The gear selection mechanisms are sequential, with separate mechanically actuated reverse / neutral baulking mechanisms. The gear selection order is Rev - Neutral - 1st 2nd 3rd 4th 5th & 6th (If applicable).

The drive is taken from the engine via the clutch shaft, which turns input and pinion gears to drive the final transmission assembly.

Gear changing is effected through non-synchronising face dogs. An extensive range of gear ratios provides a wide range of gearing permutations. The gear ratios and differential assembly can easily be changed without removing the gearbox from the vehicle.

Heat treated nickel chrome steel is used to manufacture all gears and shafts. The selector forks are also steel. The gearboxes are splash lubricated.

In general configuration, the FTR family of gearboxes are high tech racing transaxle units which achieve the maximum effective use of power, in conjunction with extremely stiff integral rear suspension mountings.

Weight (Aluminium) FTR(6sp) 88 lbs (40 Kg)

JFR(6sp) 79 lbs (36 Kg)

Oil type SAE 80 or 90

Oil quantity FTR/JFR(6sp) 4.4 pints (2.5 litres)

Maximum engine torque 220 lbs.ft (298 Nm)

Crownwheel bolt tightening torque = 75 lbs.ft (100 Nm)

Engine oil tank capacity (**FTR ONLY**) 13 pints (7.5 litres)

Pinion bearing nut torque = 150 lbs.ft (205 Nm) (**FTR FORMULA BMW ONLY**) = 130 lbs.ft (176 Nm)

(See Page 89 for general K-nut tightening torques)

Gear ratios from 3.167:1 to .89:1

Final drive ratio 12/34, 9/35 or 9/31

Clutch shaft made to customers requirements

Pinion shaft nut torque (6sp) = 75 lbs.ft (100 Nm)

Pinion shaft nut torque (5sp) = 115 lbs.ft (155Nm)

## GEAR SELECTION

Up shifting is effected by moving the gear lever in a backward direction. For Downshifting the opposite is necessary. Shifting down into either neutral or reverse is prevented by a baulk plunger. So the plunger operating cable must be pulled before such a shift can be made. Up shifting is as for any other gear, as it does not require the plunger cable to be pulled.

## **GENERAL NOTES :-**

- a** Read these instructions carefully and with reference to the illustrations.
- b** Before dismantling the gearbox, see that a clean tray is available, in which to place the parts.
- c** Thoroughly clean and inspect all parts before reassembly. Discard any worn or damaged components and replace with new ones.
- d** Use only genuine Hewland parts as replacements. These are manufactured in our workshops to the fine tolerances necessary and are rigorously inspected.
- e** Always ensure that locknuts, and oil seals are in good condition when reassembling.
- f** All studs and screws must be Loctited or wirelocked in position, unless stated otherwise.
- g** Bearing Replacement :-  
Bearings can only be removed or renewed if the casings have been warmed in an oven, or with a blowlamp. In the latter case, keep the blowlamp moving while heating the casing.  
Note: Do not overheat. Test with a spot of water which will bounce off at the correct temperature.  
Once a casing is heated, all bearings should be pressed into their respective seatings without delay, thus eliminating the need to reheat. At the correct temperature, fitting the bearings should present no difficulty.  
During cooling, or when the casings have cooled, it is advisable to once more lightly press the bearings to ensure that they are correctly seated. Removal of the existing bearing outer races from the maincase and sideplate can be achieved by locally heating the area of the casings around the bearing outer races with a blowlamp, as above. Light mallet blows around this area will cause the bearing outer to drop away from its location face, it can now be tapped from behind it to remove it.  
Care must be taken not to damage the shims and spacer located under the race face.
- h** Oil:  
Fill the gearbox through the plug hole on top of the bearing carrier. The oil will find its own level within the gearbox.  
Note: Too much oil will not directly cause any harm, but is undesirable as it may induce power loss and overheating of internals.



## **CW& Pinion backlash setting** **And Differential bearing pre-load setting**

Special Tools Required: SK-1718-A, SK-1718-B (for JFR use SK-2066), SK-1715 and SK-1913-A

### **a) Determine the correct fixture settings to achieve the correct backlash at a given bearing pre-load.**

(See illustrations on following pages)

It is assumed that the pinionshaft is fitted and set at the correct position inside the maincase.

Build the differential and then press the bearing inners (7) onto the journals and mount the crownwheel onto it. Fit spacer (22) into the maincase bearing bore, followed by a nominal amount of shim (21). A good starting point is probably 0.040"

Fit the dummy bearing outer track SK-1715 to the maincase followed by the diff assembly. Fit the second dummy bearing outer track SK-1715 to the setting fixture and position onto the maincase. Secure the fixture to the maincase using all 12 nuts (55) and torque to the value specified on the k-nut tightening torque page. Ensure that the pinionshaft does not run out of backlash whilst tightening the sideplate fixing nuts and add shim if necessary.

**Please note that it is important to use all nuts torqued to the correct setting, as this affects backlash readings.**

Fit the nut (SK-1718-A) to the setting fixture (SK-1718-B or SK-2066 for JFR) and wind it by hand into position behind the bearing until a firm 'stop' is felt. Use a suitable rod to engage in the hole in the nut if necessary. Unwind the nut by a quarter turn, then whilst rotating the pinionshaft backwards and forwards, wind the nut in by hand until a firm stop is felt. This is important as it ensures the diff is correctly seated in its bearings. With a marker pen mark the position of the '0' line on the nut on the setting fixture.

**This is the 0 bearing pre-load point.**

Undo the setting fixture nuts (55) by half a turn or so to release the pressure from the maincase. Wind the nut (SK-1718-A) back into the fixture to the position where the line marked on the fixture lines up with the number on the nut that equates to the pre-load that is required.

The nut has a number of lines scribed on it and the number next to it is the pre-load in thousandths of an inch. For example 10 equates to 0.010".

With the nut set at the required bearing pre-load, secure the fixture to the maincase using all 12 nuts (55) torqued to the value specified on the k-nut tightening torque page.

Then fit tool SK-1913-A to the spline on the pinionshaft and secure it in position with an M6 cap screw. Measure the backlash at the indicated position on tool SK-1913-A.

Rotate the pinionshaft 30° or so and take another reading. Repeat this process until the difference between the minimum and maximum readings is the same as the value for the average backlash variation on the setting sheet.

If the minimum reading is outside of what is specified on the spiral bevel setup card, alter the shim (21) inside the maincase. Increasing the shim thickness will reduce the backlash, decreasing it will increase the backlash. (See Fig.1)

**Run through procedure described above until the backlash is within specification.**

**b) Calculate correct shimstack.**

**Sideplate shimstack.**

With the setting fixture secured in position and backlash having been set correctly, measure DIM A using a depth micrometer. This is the distance from the end of the nut to the top face on the setting fixture.

Record this dimension.

DIM A		"
-------	--	---

Measure & record DIM B with a height gauge.

DIM B		"
-------	--	---

Record DIM C (this is etched on the face of the nut)

DIM C		"
-------	--	---

Record DIM D (this is etched on the face of the setting fixture)

DIM D		"
-------	--	---

Calculate the total thickness of spacer & shimstack to be fitted to the sideplate:

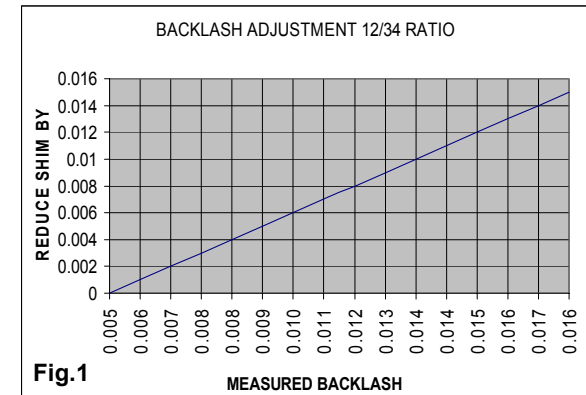

$\text{TOTAL SIDEPLATE SHIM + SPACER THICKNESS} = \text{DIM A} + \text{DIM B} + \text{DIM C} - (\text{DIM D} + 0.005")$
---

**Maincase shimstack.**

The maincase shimstack to be fitted with the standard bearing outer track (7) rather than the dummy bearing outer track SK-1715 is simply that fitted already minus 0.005". So simply remove 0.005" from the shimstack used in above section.

**c) Finalise the assembly & check backlash.**

Fit the spacers and shimstack calculated above together with the standard bearing outer tracks to the maincase and sideplate. Allow casings to cool to room temperature and fit diff and sideplate and secure with nuts (55) tightened to the value specified on the k-nut tightening torque page.

Check that the backlash is within specification.

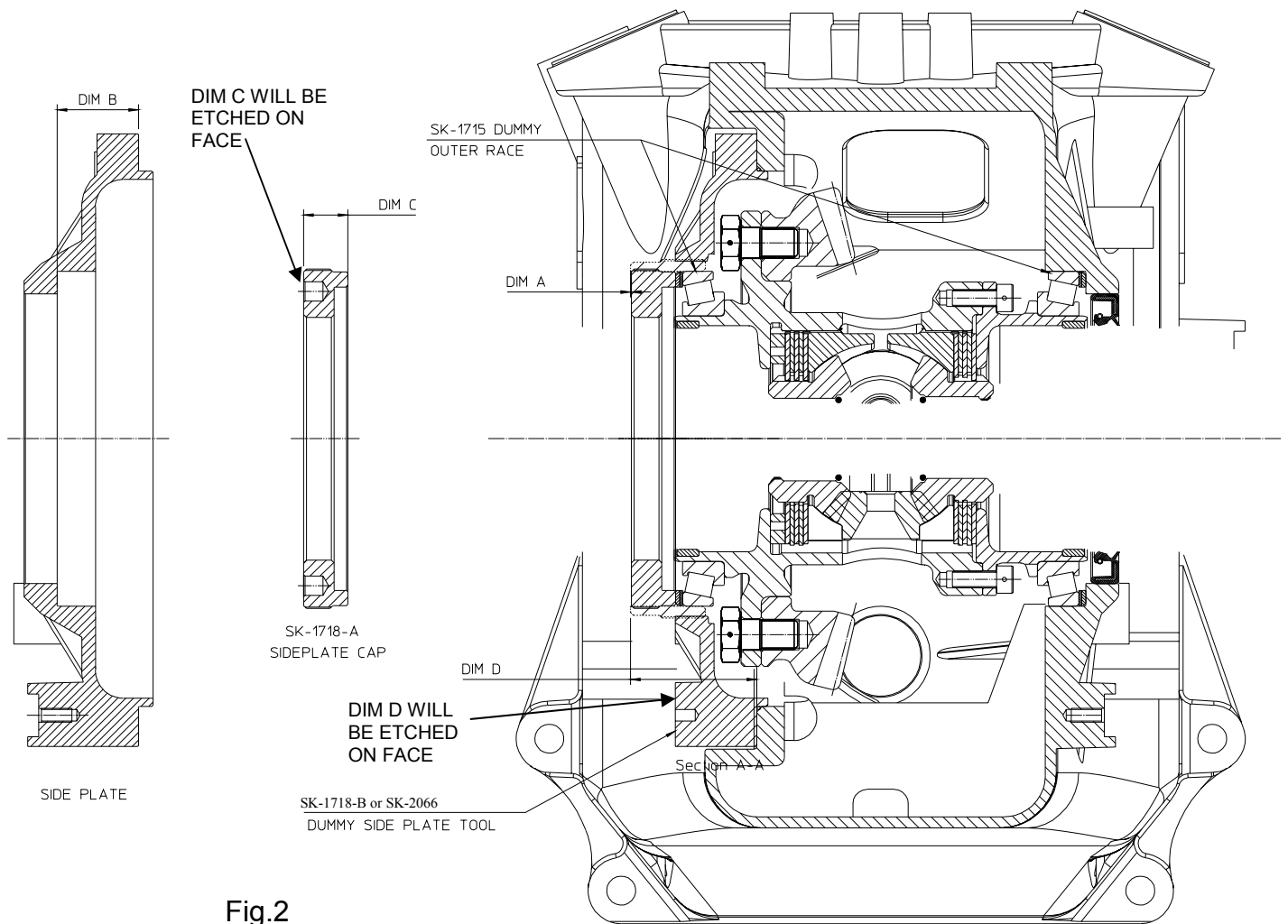

**Fig.2**  
(FTR shown)

## **PINION SETTING**

Requires special tool No.SK-1709

Press the pinion head bearing (57) front inner race onto the pinion shaft (29). Fit the bearing housing (57) and shims (59) into the maincase, and secure with washer and nut. Use socket (SK-247) to tighten the pinion bearing nut to the correct torque (see page 7). Assemble the pinion shaft into the maincase (16), add the pinion head bearing rear inner race, spacer, hubs and bearing inner tracks, pinion tail bearing and pinion shaft nut. Tighten the pinion shaft nut (71) onto the pinion shaft to the correct torque setting using the splined socket and reaction bar.

Fit tool SK-1709 into the maincase diff bearing bore, and use feeler gauges to measure the gap between the tool and the pinion front face. This clearance should comply with the dimension indicated on the pinion shaft label (also etched on the front face of the pinion shaft), and can be adjusted by adding or removing shims (59) from behind the pinion head bearing housing (57).

Alternatively, the pinion mounting distance can be measured with a height gauge, and set to the dimension on the pinion shaft label.

### Notes:

- 1 It is not correct practice to replace a pinion shaft without measuring the setting distance, **even if the old and new shafts have the same calibration.**
2. The fork setting should always be checked after replacing or re-shimming the pinion head bearing. Failure to do so may result in poor shift quality, and damaged parts.

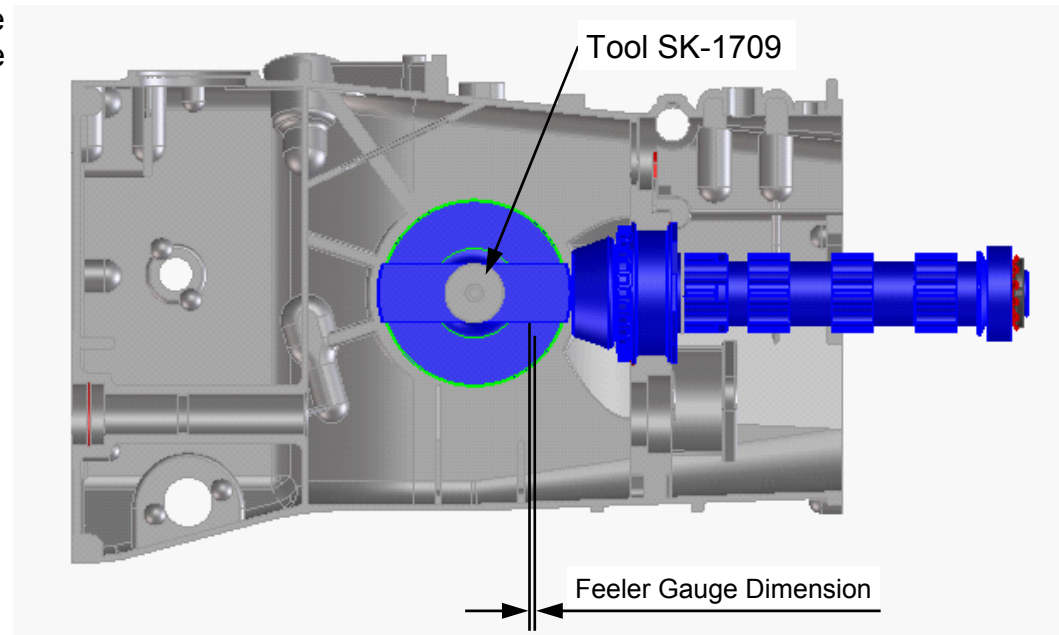

## SEQUENTIAL FORK SETTING

The FTR family sequential fork setting procedure is unique amongst Hewland sequential transaxles to date. Previous designs have been fork set by means of a barrel positioning spacer. The FTR family is set by moving the hubs along the pinion shaft by means of a spacer.

This fork setting procedure must be carried out each time the pinion head bearing is replaced or re-shimed.

- a/ Assemble the entire ratchet, barrel, and detent assembly into the maincase.
- b/ Slide the fork setting spacer, hubs, clutch rings, forks, bearings, inner tracks, and pinion shaft gears into position on the pinion shaft, and secure with the pinion shaft nut.
- c/ Engage the selector forks (44) into the barrel (use special tool SK-1716) and slide the selector rail through the forks to engage the maincase.
- d/ Rotate the barrel to engage reverse or neutral. Measure and record the gap between the dogfaces of all gears. Any difference between the dog gap measurements must be averaged out by replacing the barrel spacer (35) with one of the correct thickness.  
Note: It is not possible (or necessary) to individually adjust each fork.

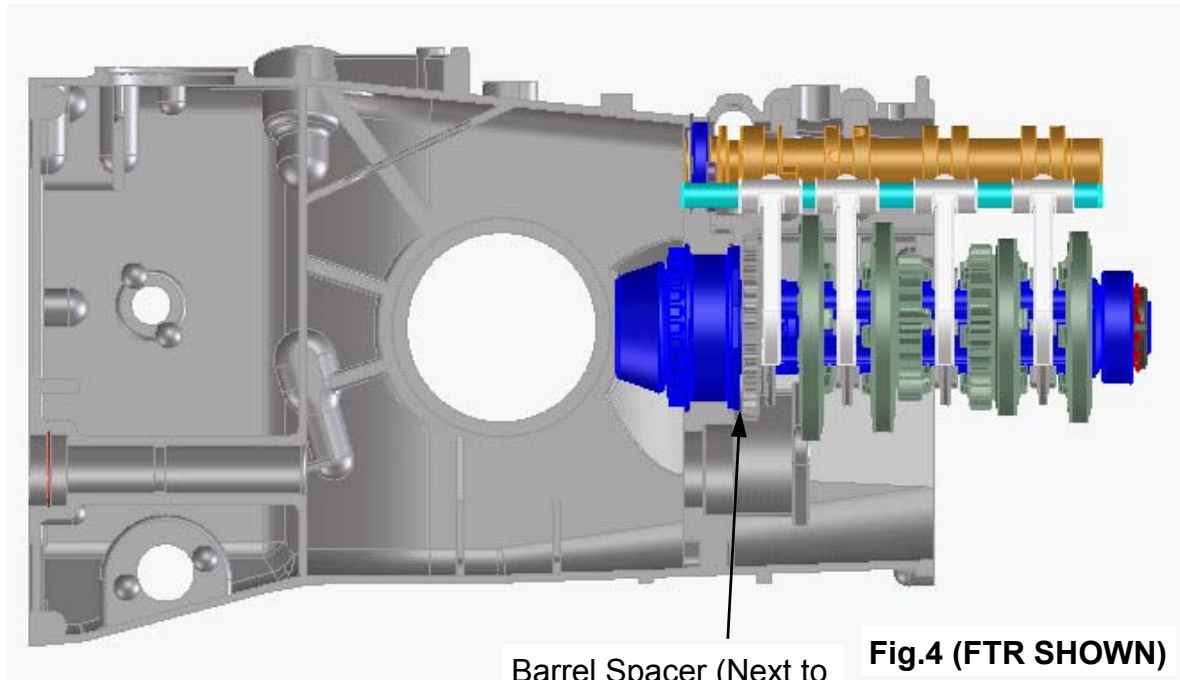

## **CHANGING GEAR RATIOS**

- a With a drip tray placed beneath the gearbox, remove the nuts from the rear cover studs, tap the bearing carrier to break the seal, and drain the oil.
- b Remove the bearing carrier.
- c Remove the circlip, locking washer and then undo the pinion shaft nut. Withdraw the selector rail about 3/4" until it becomes disengaged from the maincase, then move it to the left to disengage the selector forks from the barrel. Slide the whole gear cluster, together with the selector rail & forks, onto the fixture.
- d Remove the selector rail, followed by the gear pairs and other components.
- e Replace the gears with the required ratios. Gears are supplied in matched pairs, one for the mainshaft and one for the layshaft. Each gear is marked with two sets of numbers. The first of these indicates the number of teeth on the layshaft gear, while the second figure signifies the number of teeth on the mainshaft gear which mates with it. Both gears of each pair are marked in an identical manner. It is essential that gears are correctly paired to these numbers. Note: On all first gears, and some second gears, the gear teeth are machined integral with the layshaft. In such cases, therefore, if a first (or second) gear ratio change is required, the layshaft itself must be changed. Whilst changing ratios it is advisable, as a matter of course, to wash and inspect all components which are to be used again before refitting. Check for wear and cracks, particularly to the clutch rings. Also examine the selector forks for heavy or uneven wear.
- f Reassembly is the reverse of disassembly. Take care, when refitting the gear cluster into the maincase, to ensure location of the layshaft into its front bearing. [Some mechanics find assembly easier if the layshaft bearing inner track is pre-fitted in the casing, rather than onto the end of the layshaft.] Special tool SK-1716 is available to help align each selector fork with its groove in the barrel. Slide the selector rail forwards to engage in the maincase. Check that all of the selector forks are correctly located in the barrel.

Please note that the order of the gear ratios from the pinion head end are 1st, 2nd, 6th, 5th, 4th and 3rd

## POWERFLOW DIFFERENTIAL

This powerflow differential unit is designed with versatility as it's major asset. Many factors will contribute to the settings required. A car with good traction and low power, may require a completely different arrangement to that of a car with poor traction and high power.

There are 10 friction plates within the unit 4 splined to the diff casing, and 6 splined to the side bevel gears. Slip limiting is dependant on the friction resistance between these plates, and is affected by clamping the plates together.. Four factors contribute to the total friction torque between the plates :-

- 1 The side bevel gears thrust apart to clamp the plates as they transmit the driving power. This is a feature of the gear geometry, and is not adjustable.
- 2 The ramp angles cut on the side ring gears have an effect on how much of the transmitted torque is converted into sideways (clamping) force onto the plates. For example, on the drive side ramp, 45 degrees transmits less sideways force than 30 degrees. Likewise on the coast side ramp, an 80 degree angle will transmit little or no clamping force onto the plates, whereas a 45 degree angle will transmit a much greater force. Side ring gears are available with many different drive/coast ramp angle combinations.

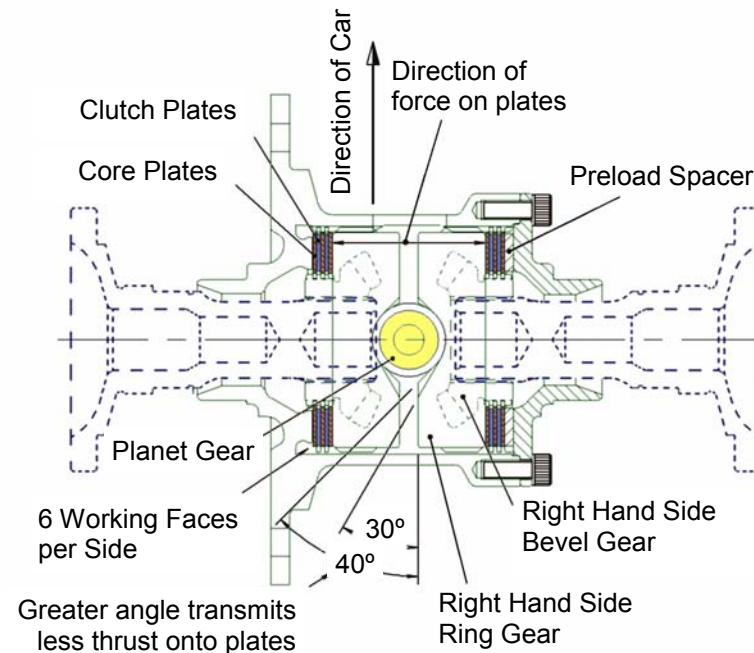

**Fig.5**

- 3/ The second adjustable factor is how tightly the plate stack is compressed on assembly (known as static preload). Included in the plate stack is a preload spacer. The preload torque is measured between the side bevel gears, by holding one side bevel gear stationary, and measuring the torque required to turn the other using tools SK-1710-A & SK-1710-B. When the diff is assembled, the preload torque must be at least 10 lbs.ft, but can be much greater if required. New plates 'run in' so a higher preload is advised than with used plates. To assist in determining the size of the preload spacer set up shims may be used. They are available in 5 different sizes, .003" .005" .008" .010" .015"
- 4/ The final adjustment is simply to re-order the plate stack so as to change the number of relatively rotating faces. The diagram shows the stack setup with the maximum 12 working faces. Standard stack may be shuffled to give as few as 2 working faces.

## **FTR-212-ADJ BACKLASH ADJUSTMENT**

The end float in the tripods determines the amount of backlash in the bevel gears. This end float is changed by machining the top hats (215) as shown below.

Set up the differential as shown in the assembly below (Fig 6).

Torque the centre bolt (214) to 25Nm and measure the tripod end float. There should be 0.025"-0.030" of end float. If there is more than this, remove material from the spacers so to achieve the require end float. The top hats are deliberately manufactured so that the initial amount of end float is greater than the end float required. When the correct amount of end float is achieved torque and Loctite (No. 648) the centre bolt (214).

Item numbers refer to page 53

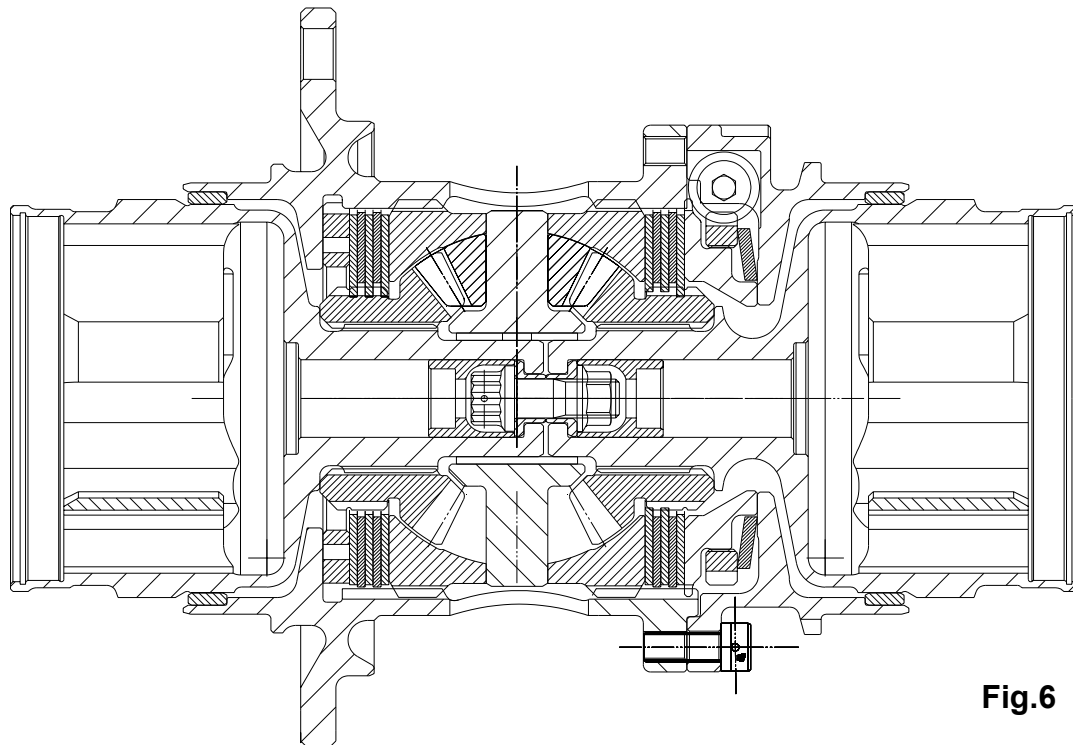

**Fig.6**



## DIFFERENTIAL TOOLS

The FTR-212-ADJ has the advantage of allowing external preload adjustment by the turning of a worm screw.

To adjust the preload of the differential, insert tool SK-1623 into the worm and turn anti-clockwise to compress the spring to increase the preload. Turn the worm clockwise to decompress the spring and decrease preload.

The maximum preload that can be wound onto the differential whilst using 12 friction surfaces is roughly 130lbsft. Fewer friction surfaces will not allow such a large preload figure.

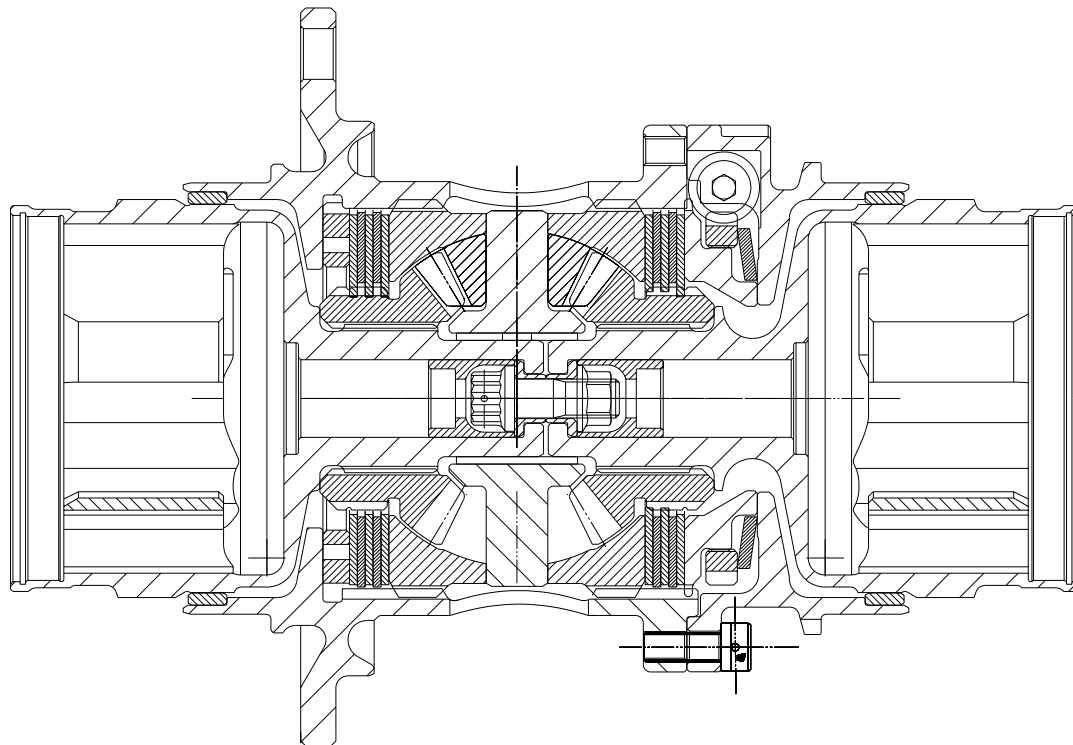

SK-1623  
DIFF ADJUSTMENT TOOL

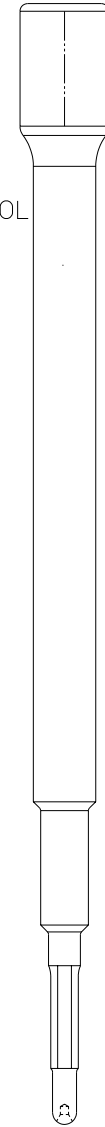

SK-2323  
WORM RETAINING TOOL

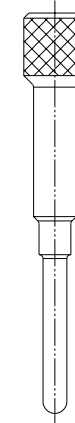

## **GEARBOX - ASSEMBLY**

- a** It is assumed that all bearings, oil seals, studs, and dowels are already fitted into casing.
- b** Slide the rearmost tophat bush into place in the maincase, then slide it rearwards as far as it will go. Push the other tophat bush into place in the maincase. Press the bearing into the reverse idler gear (39), slide the sleeve into the bearing and position the gear between the tophat bushes. Apply loctite to the retaining bolt and tighten into place.
- c** Fit the pinion shaft and head bearing assembly to the maincase.
- d** Press the dowel into the maincase. Assemble the detent arm, trunion, washer and spring into the maincase and secure with screw.
- e** Position the pawl in the slot in the selector rack. Press the pin into place, ensuring that it isn't left protruding outside the rack outer diameter. Slide the washers, spring, and sleeve onto the rack, and secure with circlip. Carefully fit the rubber seal onto the rack, taking care that it sits squarely, not twisted, in its groove. Oil liberally, and slide the rack into the maincase. Ensure that the rack is free to slide back and forth in the maincase. Any stiction here may cause shift problems in service.
- f** Put one spacer on the barrel. (*Early barrels only*). Hold the detent arm against its spring using a pair of pliers. Using a thin rod or stiff wire, push the free end of the pawl upwards in the maincase and hold it there whilst sliding the barrel into place. Slide on the second spacer (*Early barrels only*), and secure the barrel with the circlip.
- g** Slide the plunger, spring, and washer into the selector rack, and secure with circlip. Fit the oring to the selector rack stop, slide the rack stop into the casing and secure with circlip.
- h** Assemble the bell crank, bearings, spacer, and washers to the maincase, and secure with bolt. Note: Select washers of a thickness so as not to load the casting lugs when tightening the bolt. This could cause casting damage. Ensure that the selector operates smoothly in both directions, and self returns to its normal position.
- i** Add the baulking plunger, o'ring, spring, and cap. Note: when installing the gearbox in the car, the baulk release cable length should be adjusted so that the baulking plunger is held just clear of the barrel (when a forward gear is selected).
- j** Fit the wire clip onto the clutch shaft, and push the clutch shaft into the spigot bearing from the gear cluster end. The

wire clip is only fitted to hold the clutch shaft in position when changing ratios. It serves no purpose when the gearbox is fully assembled.

- k** After adjusting the differential bearing preload and crownwheel backlash. Oil the taper roller bearings then load the differential assembly in through the sideplate bore, add the sideplate and secure with nuts.
- l** The gear cluster can be built up directly into the gearbox as described below, or built up onto fixture SK-1703.
- m** Slide the spacer and reverse hub onto the pinion shaft. Assemble reverse selector fork onto the reverse pinion gear, then slide them onto the reverse hub. Allow the reverse fork head to rest against the inside of the maincase.
- n** Slide a bearing inner track and bearing onto the pinion shaft. Holding the layshaft in one hand and 1st pinion gear in the other, insert them both into position.
- o** Add a hub, clutch ring, and fork, and allow the fork to rest against the maincase. Add the bearing inner track and bearing, and slide 2nd gear pair into place.
- p** Add another bearing, and slide 6th gear pair into position, (if applicable). Add the hub, clutch ring, bearing inner track and bearings to the pinion shaft, slide the spacer onto the layshaft, then add 5th gear pair. Repeat for 4th and 3rd gear set.
- q** Slide the remaining selector forks onto their clutch rings. Insert the selector rail through all the forks, and engage it into the maincase. Special tool SK-1716 is available to help align the forks with the tracks in the barrel.
- r** Add the thrust washer, bearing inner race, and nut to the pinion shaft. Tighten the nut to the correct torque setting, then fit the locking ring and secure with circlip, or fit split pin through the nut.
- s** Add the bearing inner track spacer to the layshaft, and fit the bearing inner track into the rear cover. Position the rear cover and secure with nuts. Check that all gears are selectable, and that the bell crank returns freely to its rest position after each shift. Note: The layshaft is located between its two bearings and must be preload with spacer. This means that the shaft may be a little stiff to turn when the gearbox is cold.

ILLUSTRATED PARTS LIST  
FOR 6 SPEED CONFIGURATION OF  
FTR, FTRS, FTRL & JFR.  
(NOT INCLUDING FTRE RATIOS)

**CASINGS & ASSOCIATED PARTS- 6 SPEED  
(NOT SUITABLE FOR USE WITH FTRE RATIOS)**

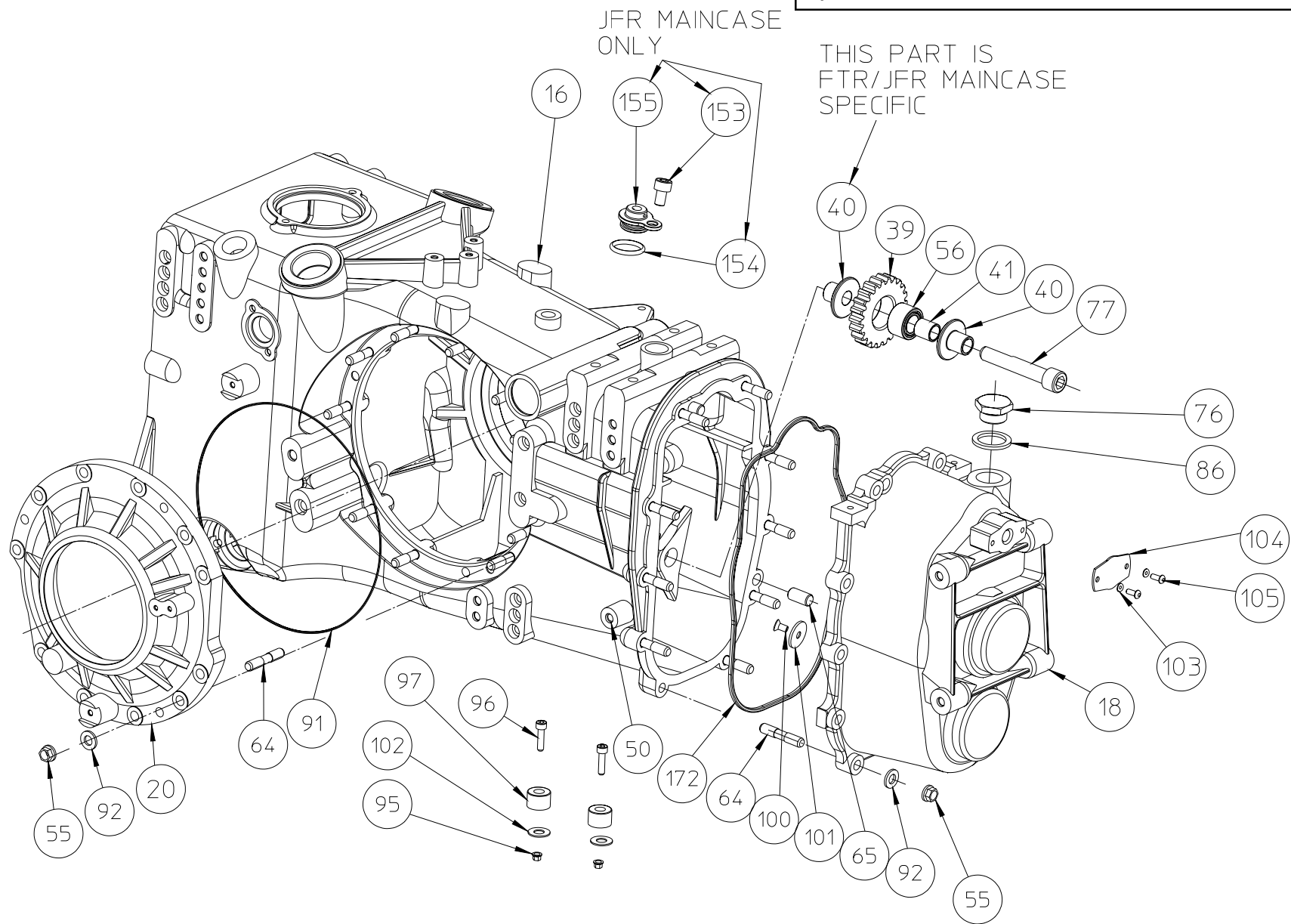

**LAYSHAFT ASSEMBLY—6 SPEED  
(NOT SUITABLE FOR USE WITH FTRE RATIOS)**

The order of the gear ratios from the pinion head end are 1st, 2nd, 6th, 5th, 4th and 3rd

Note orientation of bearing inner track and spacer

SPACER SUPPLIED WITH BEARING (MAY NEED MODIFICATION ON ASSEMBLY)

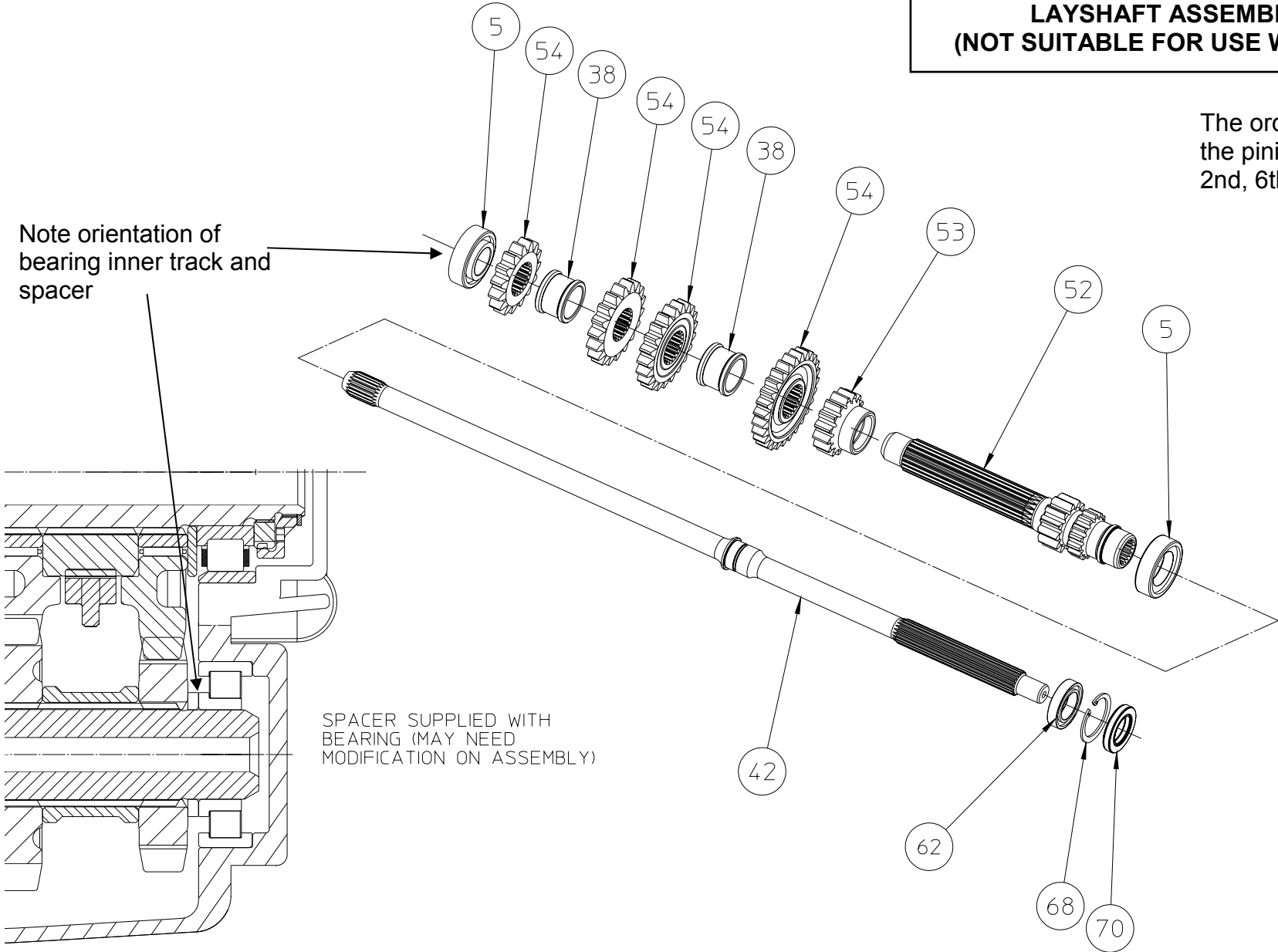

**Fig.9**

**PINION SHAFT ASSEMBLY - 6 SPEED  
(NOT SUITABLE FOR USE WITH FTRE RATIOS)**

The order of the gear ratios from the pinion head end are 1st, 2nd, 6th, 5th, 4th and 3rd

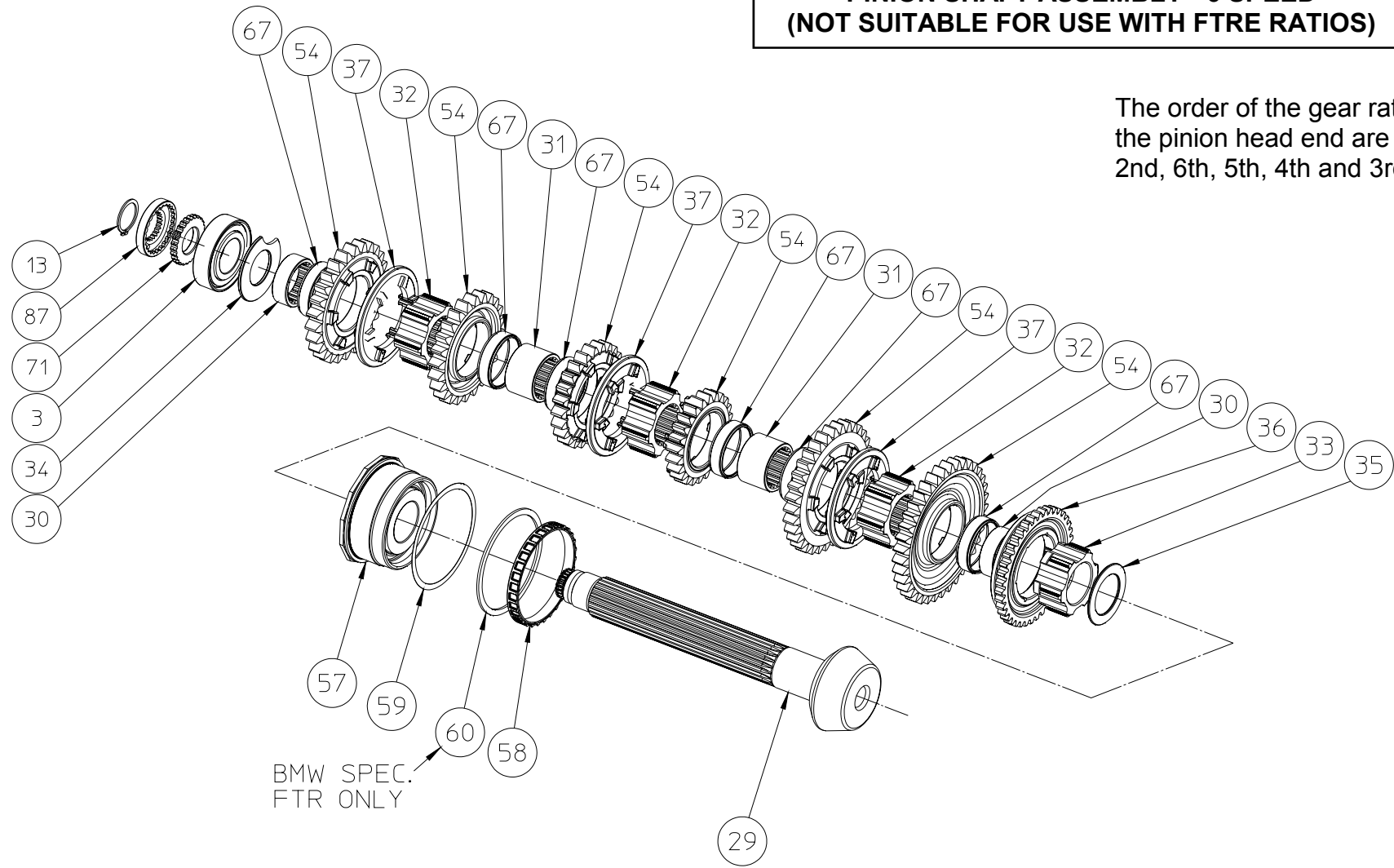

**Fig.10**

**SELECTOR ASSEMBLY—6 SPEED  
(NOT SUITABLE FOR USE WITH FTRE RATIOS)  
FOR ALTERNATIVE LIGHTWEIGHT SELECTOR  
SYSTEM SEE PAGE 28**

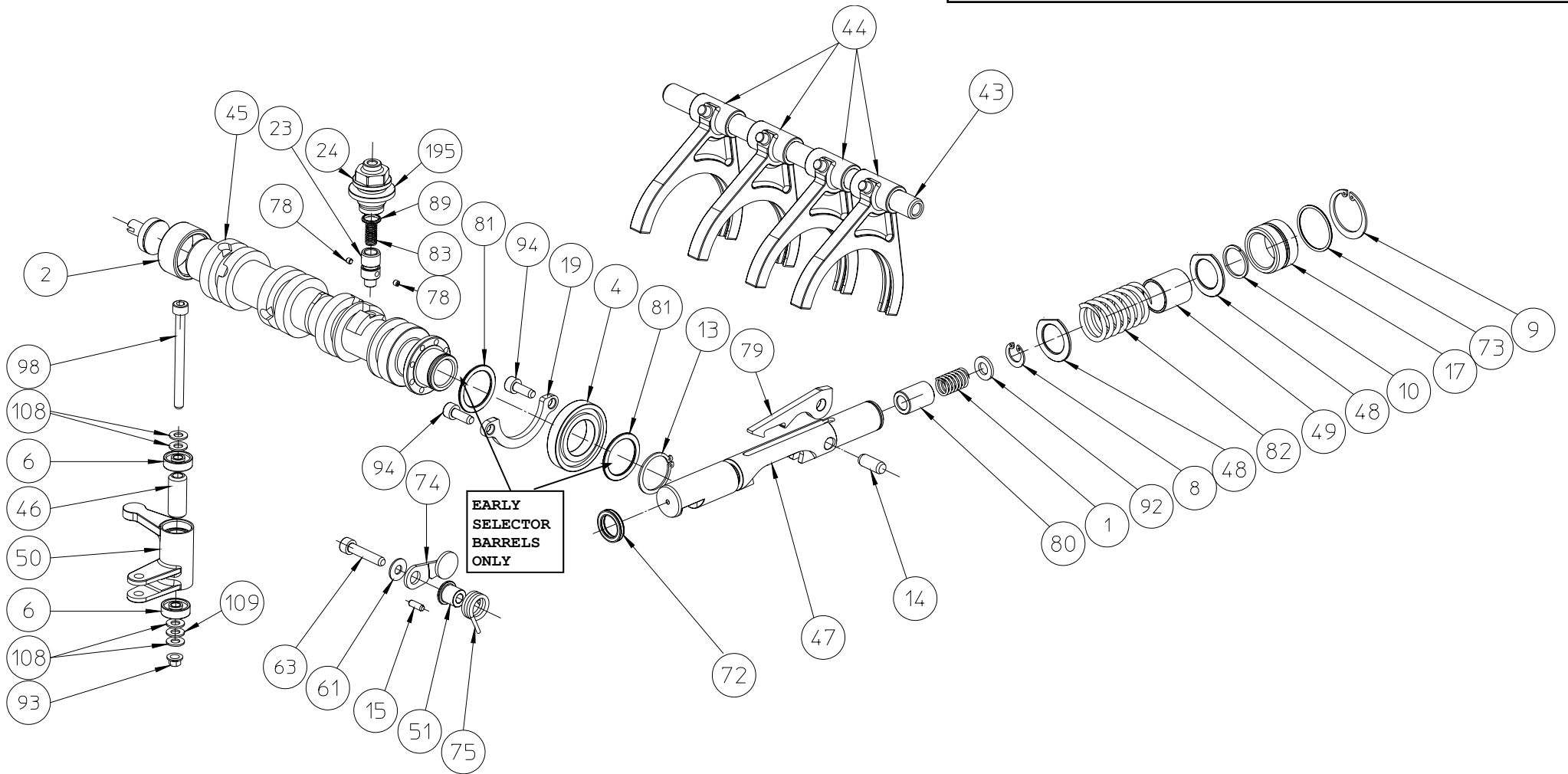

**Fig.11**



6 SPEED PARTS LIST (NOT SUITABLE FOR USE WITH FTRE RATIOS)

FTR/JFR 6 SPEED ASSEMBLY				FTR/JFR 6 SPEED ASSEMBLY			
Position	QTY	Part Number	Description	Position	QTY	Part Number	Description
1	1	102-260-9	COMPRESSION SPRING	29	1	FINAL-DRIVE	FINAL DRIVE ASSY
2	1	105-260-6	NEEDLE ROLLER BEARING	30	2	FTR-225	BEARING INNER TRACK
3	1	BEA-002	ROLLER BEARING	31	2	FTR-226	BEARING INNER TRACK
4	1	BEA-141	BALL BEARING	32	3 (FTR)	FTR-227	HUB
5	2	BEA-159	ROLLER BEARING		3 (FTRL)	FTRL-227	
6	2	BEA-162	BALL BEARING	33	1 (FTR)	FTR-228	REVERSE HUB
7	2	BEA-171	TAPER ROLLER BEARING		1 (FTRL)	FTRL-228	
8	1	CIR-082	CIRCLIP	34	1	LD5-229-4	SPACER
9	1	CIR-083	CIRCLIP	35	1	FTR-229-1	FORK SETTING SPACER
10	1	CIR-084	CIRCLIP	36	1 (FTR)	FTR-231	REVERSE SLIDING GEAR
13	2	DGB-239-0	EXTERNAL CIRCLIP		1 (FTRL)	FTRL-231	
14	1	DOW-024	DOWEL	37	3	FTR-232	CLUTCH RING
15	1	F3A-202-9A	DOWEL	38	2 (FTR)	FTR-234-1	SPACER-INPUT SHAFT
16	1 (FTR)	FTR-201	MAINCASE		2 (FTRL)	FTRL-234-1	
	1 (JFR)	JFR-201					
17	1	FTR-201-1	SELECTOR RACK STOP	39	1	FTR-237	REVERSE IDLER GEAR
					1	FTRL-237	
18	1	BEARING-CARRIER	BEARING CARRIER	40	2 (FTR),	FTR-237-1	REVERSE IDLER SPIGOT
19	1	FTR-202-2	BEARING RETAINING PLATE		1 (JFR)		
20	1 (FTR)	FTR-205	SIDEPLATE	40	1 (JFR)	JFR-237-1	REVERSE IDLER SPIGOT
	1 (JFR)	JFR-205		41	1	FTR-237-2	SLEEVE
21	2	FTR-205-1	SIDEPLATE SHIM	42	1	FTR-239	CLUTCH SHAFT
22	2	FTR-205-2	SIDEPLATE SPACER	43	1	FTR-246	SELECTOR RAIL
23	1	FTR-210-35	PLUNGER	44	4	FTR-250	SELECTOR FORK
24	1	FTR-210-36	PLUG	45	1 (FTR)	FTR-260	SELECTOR BARREL ASSY
25	1	DIFFERENTIAL-ASSY	DIFF ASSY		1 (FTRL)	FTRL-260	
26	2	OUTPUT-FLANGE	OUTPUT FLANGE	46	1	FTR-260-2	SPACER TUBE

PARTS DESIGNATED "FTRL" ARE LIGHTENED ALTERNATIVES THAT CAN BE FITTED AS DIRECT REPLACEMENTS FOR STANDARD PARTS.

**6 SPEED PARTS LIST Continued (NOT SUITABLE FOR USE WITH FTRE RATIOS)**

FTR/JFR 6 SPEED ASSEMBLY				FTR/JFR 6 SPEED ASSEMBLY			
Position	QTY	Part Number	Description	Position	QTY	Part Number	Description
47	1 (FTR)	FTR-260-3	SELECTOR RACK	68	1	LD-244-10	CIRCLIP
	1 (FTRL)	FTRL-260-3		69	2	LIP-042	OIL SEAL
48	2	FTR-260-4	SELECTOR RACK WASHER	70	1	LIP-043	OIL SEAL
49	1	FTR-260-5	SLEEVE	71	1	LOCK NUT (PIN.TAIL)	LOCK NUT (PIN.TAIL)
50	1	FTR-260-7	BELL CRANK	72	1	ORI-085	QUAD-RING
51	1	FTR-260-8	SPRING TRUNION	73	1	ORI-097	O-RING
52	1 (FTR)	FTR-234-ASSY	LAYSHAFT ASSEMBLY	74	1	PCT-260-2	DRUM STOPPER
	1 (FTRL)	FTRL-234-ASSY		75	1	PCT-260-3	COIL SPRING
53	1 (FTR)	FTR-RATIO-HUB	HUBBED GEAR PAIR	76	1	PLU-030	PLUG
	1 (FTRL)	FTRL-RATIO-HUB + FTRL-235-1A	HUBBED GEAR PAIR (SPACER REQUIRED)	77	1 (FTR)	SCR-117	SOCKET CAP SCREW
54	4 (FTR)	FTR-RATIO-STD	STANDARD GEAR PAIR		1 (JFR)	SCR-225	
	4 (FTRL)	FTRL-RATIO-STD	STANDARD GEAR PAIR	79	1	SPH1077-M3	PAWL
55	21	NUT-004	KAYNUT	80	1	SPH1078-M3	PLUNGER
56	1	HC-237-2	NEEDLE ROLLER BEARING	81	2	FTR-260-10	BARREL SPACERS
57	1	HC8-222-1HB OR LOW FRICTION BEARING	PINION HEAD BEARING	82	1	SPR-057	COMPRESSION SPRING
58	1 (FTR)	FGA-222-1A	NUT (BMW SPEC FTR ONLY)	82	1	SPR-144	COMPRESSION SPRING (BMW SPEC ONLY)
	0 (JFR)			83	1	SPR-058	COMPRESSION SPRING
58	1	NUT-031	NUT (NOT BMW SPEC)	85	8	CROWNWHEEL-BOLT	CROWNWHEEL BOLT
59	1	HC8-222-2	SHIM	86	1	WSH-010	DOWTY WASHER
60	1 (FTR)	HC8-222-2A	WASHER (BMW SPEC FTR ONLY)	87	1	LOCKING RING (PINION)	LOCKING RING (PINION)
	0 (JFR)			89	1	ORI-001	O-RING
61	1	HP-M-7039	DRUM WASHER	91	1 (FTR)	ORI-203	O-RING
62	1	HP-M-8008	BALL BEARING		1 (JFR)	ORI-189	
63	1	HP-M-9054	SOCKET HEAD CAP SCREW	92	22	F3D-236-1	WASHER
64	21	STU-073	STUD	93	1	NUT-005	KAYNUT
65	2	LD-201-5	DOWEL	94	2	HP-N-9006	SOCKET CAP SCREW
67	6	LD-226-1	NEEDLE CAGE	95	2	NUT-007	KAYNUT

PARTS DESIGNATED "FTRL" ARE LIGHTENED ALTERNATIVES THAT CAN BE FITTED AS DIRECT REPLACEMENTS FOR STANDARD PARTS.

6 SPEED PARTS LIST Continued (NOT SUITABLE FOR USE WITH FTRE RATIOS)

<b>FTR/JFR 6 SPEED ASSEMBLY</b>			
<b>Position</b>	<b>QTY</b>	<b>Part Number</b>	<b>Description</b>
96	2	HC96-203-18	SOCKET CAP SCREW
97	2	VG-201-1A	MAGNET
98	1	HP-M-9008	SOCKET CAP SCREW
100	1	SCR-023	COUNTERSUNK SKT SCREW
101	1	WSH-051	WASHER
102	2	WSH-011	WASHER
103	2	WSH-069	PLAIN WASHER
104	1	TE-201-4	COVER PLATE
105	2	HP-M-9062	SKT BUTTON HEAD SCREW
106	2	HP-N-9004	WIRE CLIP
107	2	GAITOR-KIT (OPT)	GAITOR KIT
108	4	LD-202-9	WASHER
109	1	WSH-067	SHIM WASHER
172	1	VG-201-9	SEALING STRIP
181	1	FTR-205-4	BEARING SPACER
182	1	FTR-205-3	BEARING SPACER
183	2	HC9-205-3	BALL BEARING
184	2	CS-1628	BEARING CARRIER
185	2	HC9-205-4	OUTPUT OILSEAL
186	2	CS-1721	OUTPUT FLANGES
187	1	SPA-073	BEARING SPACER
188	1	CS-1631	BEARING SPACER
189	1	CS-1628-B	BEARING SPACER
195	1	HP-M-9042	DOWTY WASHER

PARTS DESIGNATED "FTRL" ARE LIGHTENED ALTERNATIVES THAT CAN BE FITTED AS DIRECT REPLACEMENTS FOR STANDARD PARTS.

## 6 SPEED VARIABLE PARTS

# VARIABLE PARTS

ITEM No	PART No	QTY	QTY	QTY	QTY	QTY	QTY	QTY
29	FTR-221-9:35	1	1					
	FTR-221-9:31			1		1	1	
	FTR-221-12:34				1			
	FTRL-221-12:34							1
25	FTR-212	1	1	1	1	1		
	FTRL-212							1
	FTR-212-FD						1	
26	FTR-218-8					1		
	FTR-218-1AS	1	1	1	1			1
	FTR-218-7AS					1		
	FTR-218-2	1	1	1	1			1
	FTR-218-FD						2	
85	VG-221-1	8	8					
	VG-221-1A			8		8	8	
	VG-221-1B				8			8
18	FTR-202	1	1	1	1	1	1	
	FTR-202-A							1
71	FTR-230	1	1	1		1	1	
	FTR-230-A				1			1
87	HP-M-4026	1	1	1		1	1	
	FTR-230-B				1			1
107	FTR-218-6	2	2	2	2	2	2	2
58	NUT-031		1	1	1	1	1	1
	FGA-222-1A	1						
60	HC8-222-2A	1						
82	SPR-057		1	1	1	1	1	1
	SPR-144	1						

**LIGHTWEIGHT ALTERNATIVE SELECTOR  
ASSEMBLY—6 SPEED  
(NOT FOR USE WITH FTRE RATIO'S)**

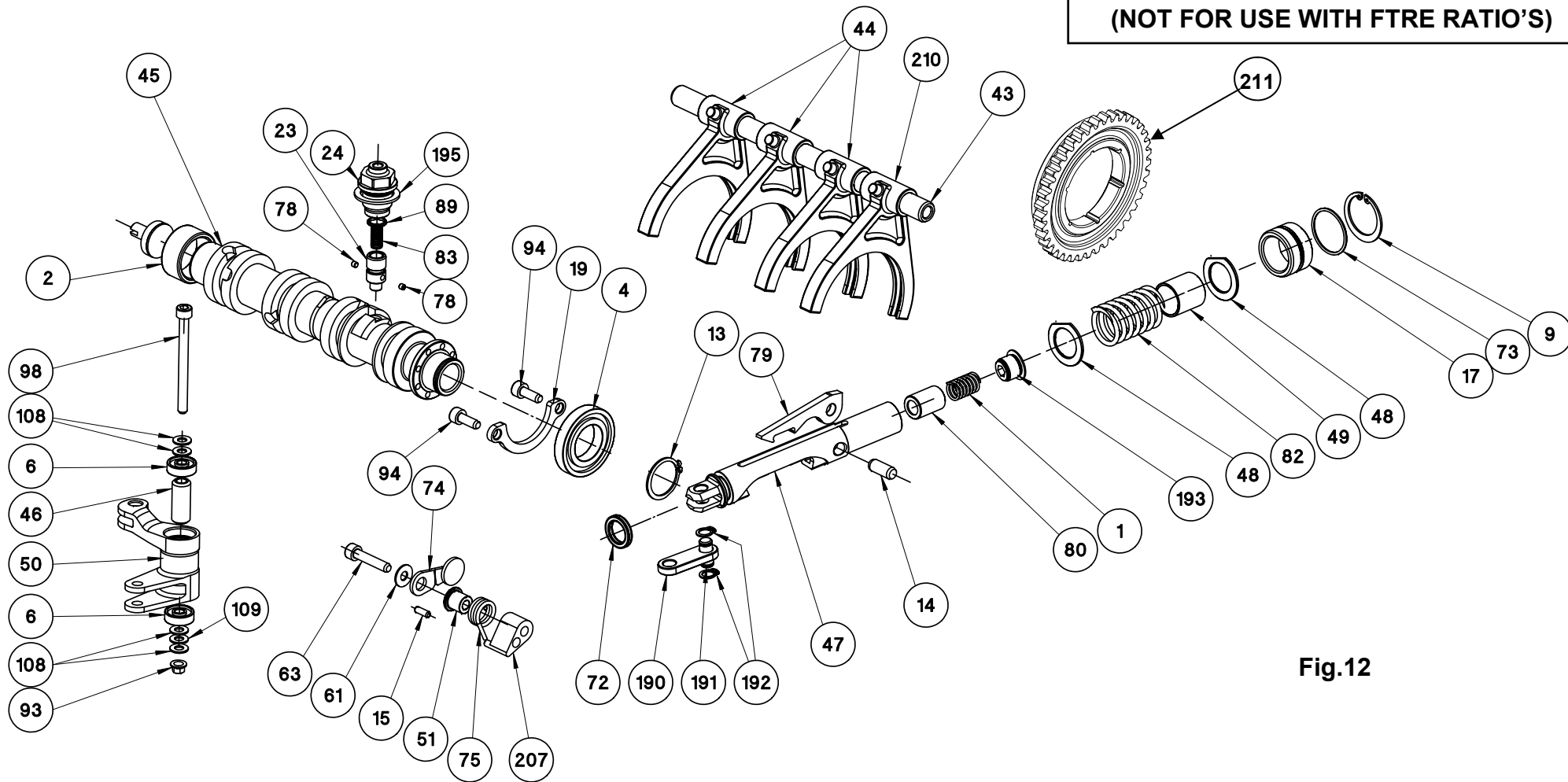

**Fig.12**

**LIGHTWEIGHT ALTERNATIVE SELECTOR ASSEMBLY—6 SPEED (NOT FOR USE WITH FTRE RATIO'S)**

FTR 6 SPEED SELECTOR ASSEMBLY USING FTREL BARREL				FTR 6 SPEED SELECTOR ASSEMBLY USING FTREL BARREL			
Position	QTY	Part Number	Description	Position	QTY	Part Number	Description
1	1	102-260-9	COMPRESSION SPRING	72	1	ORI-085	QUAD-RING
2	1	105-260-6	NEEDLE ROLLER BEARING	73	1	ORI-097	O-RING
4	1	BEA-141	BALL BEARING	74	1	PCT-260-2	DRUM STOPPER
6	2	BEA-162	BALL BEARING	75	1	PCT-260-3	COIL SPRING
9	1	CIR-083	CIRCLIP	78	2	SCR-121	SOCKET SET SCREW
13	2	DGB-239-0	EXTERNAL CIRCLIP	79	1	FTRE-260-6	PAWL
14	1	DOW-024	DOWEL	80	1	SPH1078-M3	PLUNGER
15	1	F3A-202-9A	DOWEL	82	1	SPR-057	COMPRESSION SPRING
17	1	FTR-201-1	SELECTOR RACK STOP	83	1	SPR-058	COMPRESSION SPRING
19	1	FTR-202-2	BEARING RETAINING PLATE	89	1	ORI-001	O-RING
23	1	FTR-210-35	PLUNGER	93	1	NUT-005	KAYNUT
24	1	FTR-210-36	PLUG	94	2	HP-N-9006	SOCKET CAP SCREW
43	1	FTRE-246	SELECTOR RAIL	98	1	HP-M-9008	SOCKET CAP SCREW
44	3	FTRE-250	SELECTOR FORK	108	4	LD-202-9	WASHER
45	1	FTREL-260	SELECTOR BARREL ASSY	109	1	WSH-067	SHIM WASHER
46	1	FTR-260-2	SPACER TUBE	190	1	FTRE-260-9	PIVOT PIECE
47	1	FTRE-260-3	SELECTOR RACK	191	2	FTRE-260-9A	PIVOT PINS
48	2	FTR-260-4	SELECTOR RACK WASHER	192	4	CIR-054	CIRCLIPS
49	1	FTRE-260-5	SLEEVE	193	1	FTRE-260-3A	RACK PLUG
50	1	FTRE-260-7	BELL CRANK	195	1	HP-M-9042	DOWTY WASHER
51	1	FTR-260-8	SPRING TRUNION	207	1	FTRE-201-1	PILLAR SPACER
61	1	HP-M-7039	DRUM WASHER	210	1	FTRE-249	REVERSE FORK
63	1	SCR-152	SOCKET HEAD CAP SCREW	211	1	FTRE-231	REVERSE SLIDING GEAR

DARKER COLOURS REPRESENT NEW PARTS, GREY PARTS ARE THE SAME AS THOSE WITH THE STANDARD SELECTOR SYSTEM

**5 SPEED CONVERSION OF 6 SPEED  
(NOT SUITABLE FOR USE WITH FTRE RATIOS)**

REMOVE THE FOLLOWING COMPONENTS FROM THE 6 SPEED BILL OF MATERIALS

31	1	FTR-226	BEARING INNER TRACK
38	1	FTR-234-1	SPACER-INPUT SHAFT
54	1	FTR-RATIO-STD	FTR-STD GEAR PAIR
67	1	LD-226-1	NEEDLE CAGE

ADD THE FOLLOWING COMPONENTS TO THE BILL OF MATERIALS

501	1	FTR-225	BEARING INNER TRACK
502	1	FTR-225-A	BEARING SPACER
503	1	FTR-234-1A	SPACER-INPUT SHAFT
504	1	HP-M-9036	SOCKET HEAD SCREW
505	1	NUT-030	CAPTIVE NUT

ASSEMBLE THE NEW 5 SPEED COMPONENTS AS SHOWN BELOW.

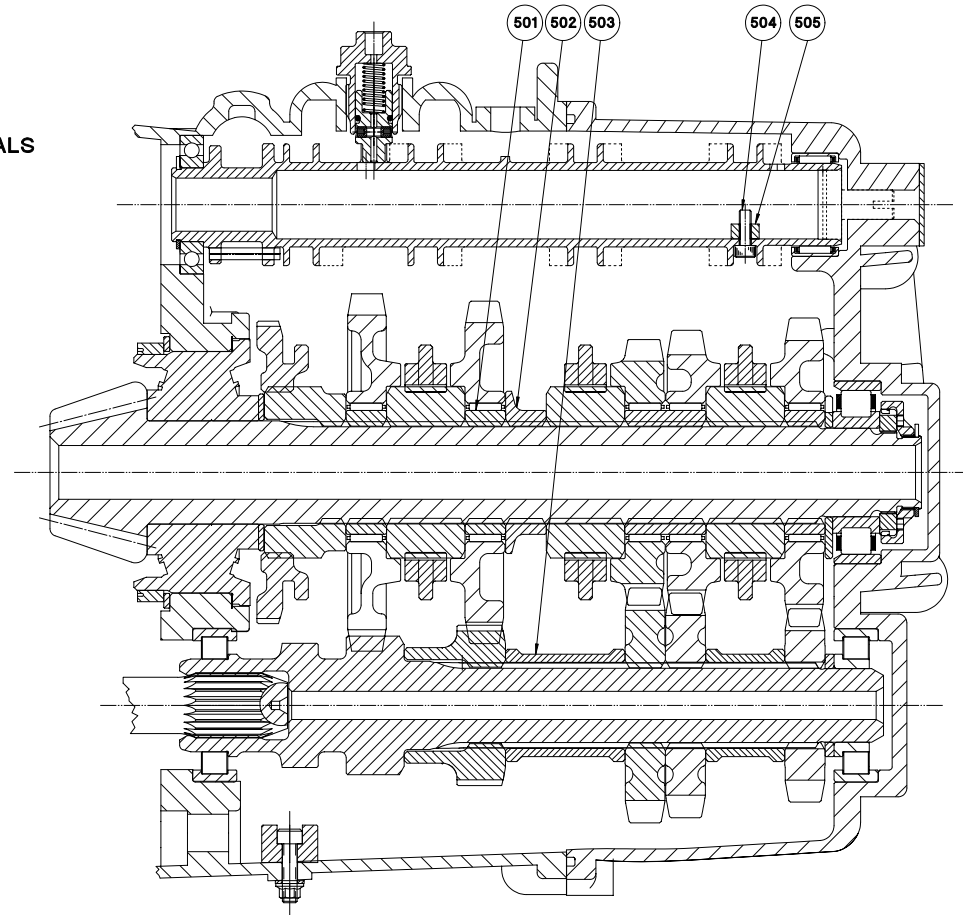

**Fig.13**

**ILLUSTRATED PARTS LIST  
FOR 6 SPEED CONFIGURATION OF  
FTR FITTED WITH FTRE RATIOS.**

**FTRE RATIO CONFIGURATION NOW  
OBSOLETE (USED IN 2008 ONLY)**



# FTRE RATIO CONFIGURATION NOW OBSOLETE (USED IN 2008 ONLY)

## CASINGS & ASSOCIATED PARTS 6 SPEED (FTRE RATIOS ONLY)

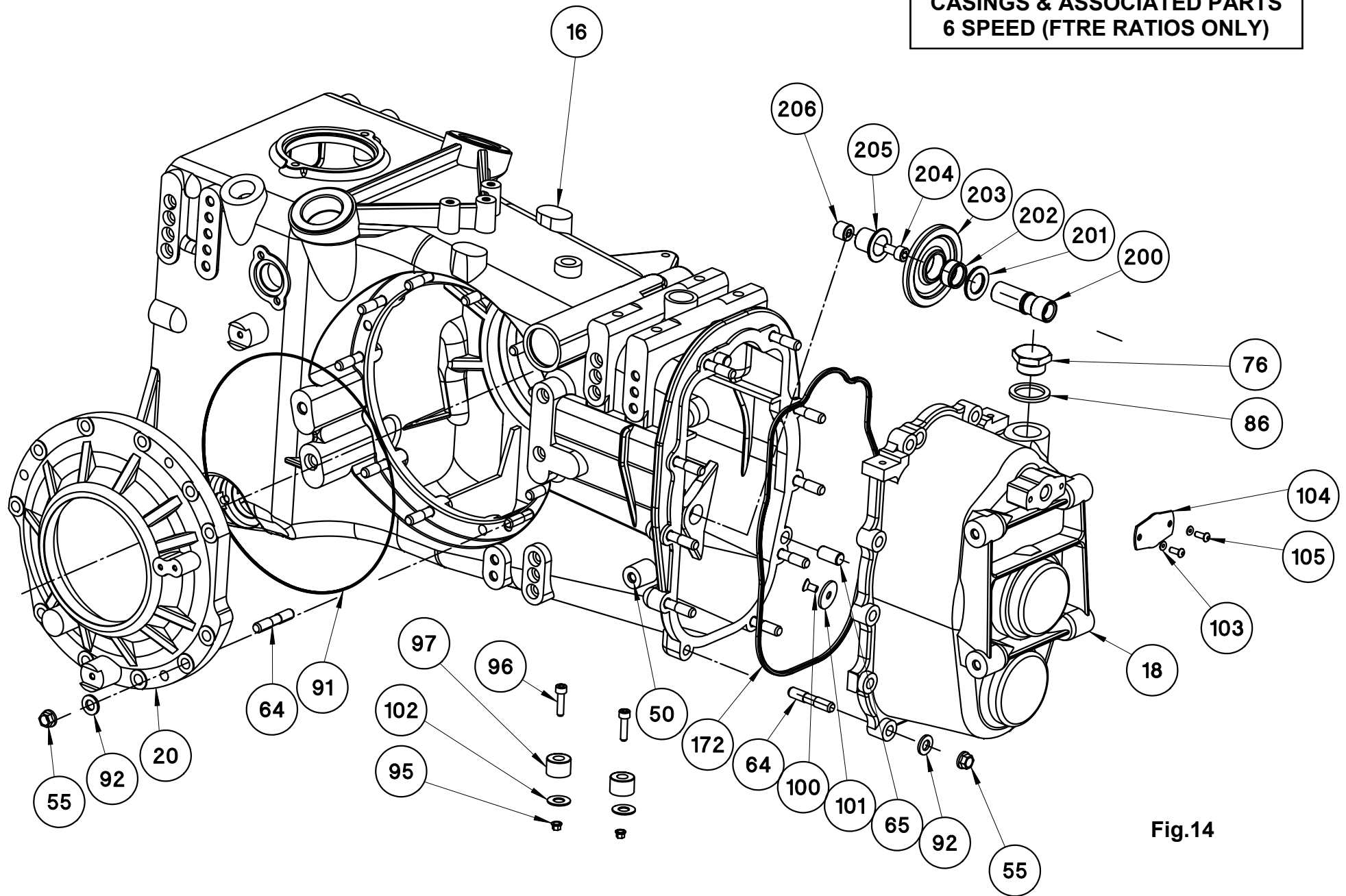

Fig.14

# FTRE RATIO CONFIGURATION NOW OBSOLETE (USED IN 2008 ONLY)

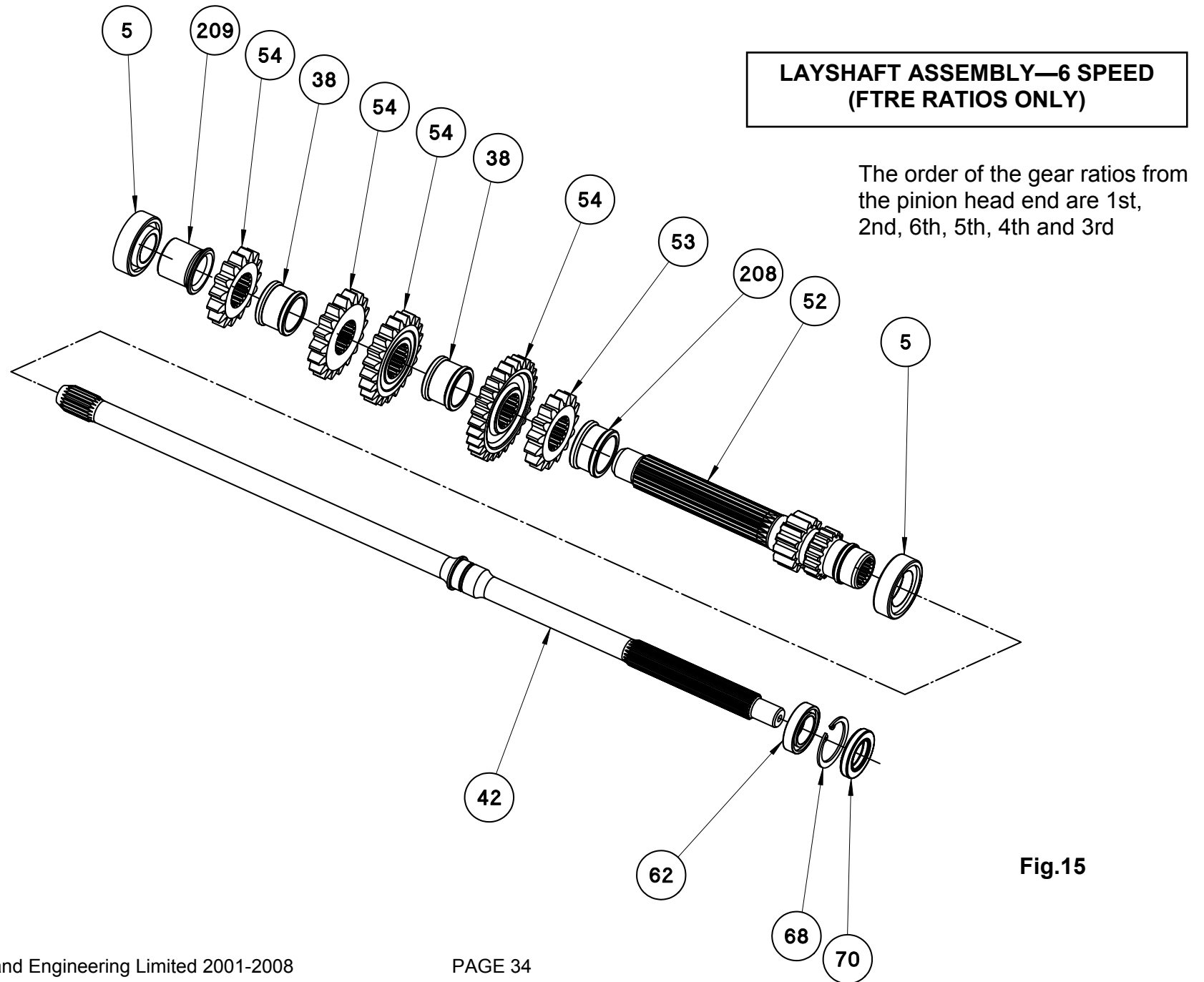

Fig.15

# FTRE RATIO CONFIGURATION NOW OBSOLETE (USED IN 2008 ONLY)

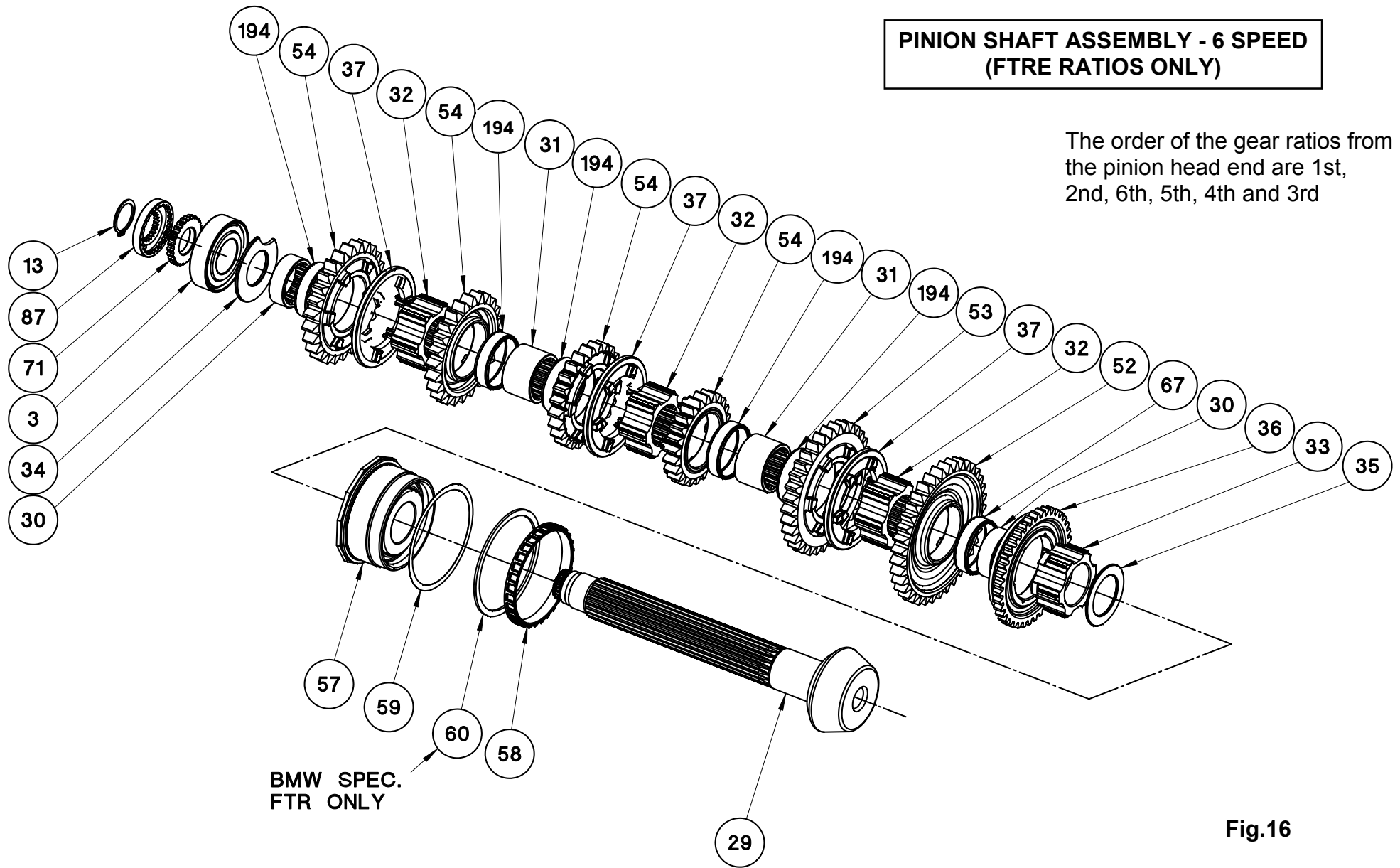

Fig.16

# FTRE RATIO CONFIGURATION NOW OBSOLETE (USED IN 2008 ONLY)

## SELECTOR ASSEMBLY—6 SPEED (FTRE RATIOS ONLY)

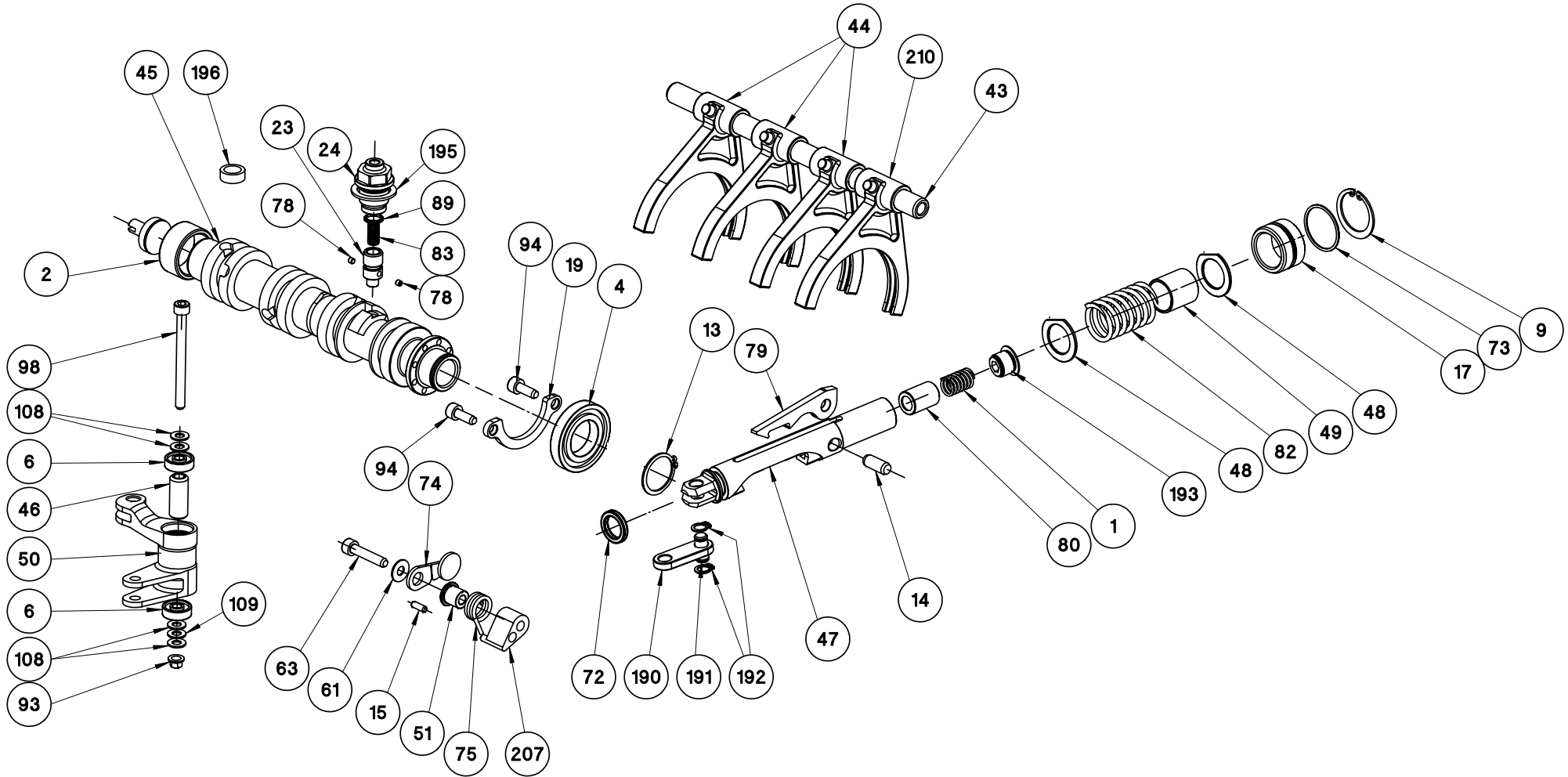

Fig.17

# FTRE RATIO CONFIGURATION NOW OBSOLETE (USED IN 2008 ONLY)

## 6 SPEED PARTS LIST (FTRE RATIOS ONLY)

FTR 6 SPEED ASSEMBLY USING FTRE RATIOS				FTR 6 SPEED ASSEMBLY USING FTRE RATIOS			
Position	QTY	Part Number	Description	Position	QTY	Part Number	Description
1	1	102-260-9	COMPRESSION SPRING	33	1	FTRE-228	REVERSE HUB
2	1	105-260-6	NEEDLE ROLLER BEARING	34	1	FTRE-224	SPACER
3	1	BEA-002	ROLLER BEARING	35	1	FTR-229-1	FORK SETTING SPACER
4	1	BEA-141	BALL BEARING	36	1	FTRE-231	REVERSE SLIDING GEAR
5	2	BEA-159	ROLLER BEARING	37	3	FTR-232	CLUTCH RING
6	2	BEA-162	BALL BEARING	38	2	FTRE-234-1	SPACER-INPUT SHAFT
7	2	BEA-171	TAPER ROLLER BEARING	42	1	FTR-239	CLUTCH SHAFT
9	1	CIR-083	CIRCLIP	43	1	FTRE-246	SELECTOR RAIL
13	2	DGB-239-0	EXTERNAL CIRCLIP	44	3	FTRE-250	SELECTOR FORK
14	1	DOW-024	DOWEL	45	1	FTRE-260	SELECTOR BARREL ASSY
15	1	F3A-202-9A	DOWEL	46	1	FTR-260-2	SPACER TUBE
16	1	FTR-201	MAINCASE	47	1	FTRE-260-3	SELECTOR RACK
17	1	FTR-201-1	SELECTOR RACK STOP	48	2	FTR-260-4	SELECTOR RACK WASHER
18	1	BEARING-CARRIER	BEARING CARRIER	49	1	FTRE-260-5	SLEEVE
19	1	FTR-202-2	BEARING RETAINING PLATE	50	1	FTRE-260-7	BELL CRANK
20	1	FTR-205	SIDEPLATE	51	1	FTR-260-8	SPRING TRUNION
21	2	FTR-205-1	SIDEPLATE SHIM	52	1	FTRE-234-ASSY	LAYSHAFT ASSEMBLY
22	2	FTR-205-2	SIDEPLATE SPACER	53	1	FTRE-RATIO-2ND	FTR 2ND GEAR PAIR
23	1	FTR-210-35	PLUNGER	54	4	FTRE-RATIO-STD	FTRE STANDARD GEAR PAIR
24	1	FTR-210-36	PLUG	55	21	NUT-004	KAYNUT
25	1	DIFFERENTIAL-ASSY	DIFF ASSY	57	1	HC8-222-1HB OR LOW FRICTION	PINION HEAD BEARING
26	2	OUTPUT-FLANGE	OUTPUT FLANGE	58	1	FGA-222-1A	NUT (BMW SPEC FTR ONLY)
29	1	FINAL-DRIVE	FINAL DRIVE ASSY		1	NUT-031	NUT (NOT BMW SPEC)
30	1	FTRE-225	BEARING INNER TRACK	59	1	HC8-222-2	SHIM
31	2	FTRE-226	BEARING INNER TRACK	60	1	HC8-222-2A	WASHER (BMW FTR ONLY)
32	3	FTRE-227	HUB	61	1	HP-M-7039	DRUM WASHER

# FTRE RATIO CONFIGURATION NOW OBSOLETE (USED IN 2008 ONLY)

## 6 SPEED PARTS LIST Continued (FTRE RATIOS ONLY)

FTR 6 SPEED ASSEMBLY USING FTRE RATIOS				FTR 6 SPEED ASSEMBLY USING FTRE RATIOS			
Position	QTY	Part Number	Description	Position	QTY	Part Number	Description
62	1	HP-M-8008	BALL BEARING	96	2	HC96-203-18	SOCKET CAP SCREW
63	1	SCR-152	SOCKET HEAD CAP SCREW	97	2	VG-201-1A	MAGNET
64	21	STU-073	STUD	98	1	HP-M-9008	SOCKET CAP SCREW
65	2	LD-201-5	DOWEL	100	1	SCR-023	COUNTERSUNK SKT SCREW
67	6	LD-226-1	NEEDLE CAGE	101	1	WSH-051	WASHER
68	1	LD-244-10	CIRCLIP	102	2	WSH-011	WASHER
69	2	LIP-042	OIL SEAL	103	2	WSH-069	PLAIN WASHER
70	1	LIP-043	OIL SEAL	104	1	TE-201-4	COVER PLATE
71	1	LOCK NUT (PIN.TAIL)	LOCK NUT (PIN.TAIL)	105	2	HP-M-9062	SKT BUTTON HEAD SCREW
72	1	ORI-085	QUAD-RING	106	2	HP-N-9004	WIRE CLIP
73	1	ORI-097	O-RING	107	2	GAITOR-KIT (OPT)	GAITOR KIT
74	1	PCT-260-2	DRUM STOPPER	108	4	LD-202-9	WASHER
75	1	PCT-260-3	COIL SPRING	109	1	WSH-067	SHIM WASHER
76	1	PLU-030	PLUG	172	1	VG-201-9	SEALING STRIP
79	1	FTRE-260-6	PAWL	181	1	FTR-205-4	BEARING SPACER
80	1	SPH1078-M3	PLUNGER	182	1	FTR-205-3	BEARING SPACER
82	1	SPR-057	COMPRESSION SPRING	183	2	HC9-205-3	BALL BEARING
83	1	SPR-058	COMPRESSION SPRING	184	2	CS-1628	BEARING CARRIER
85	8	CROWNWHEEL-BOLT	CROWNWHEEL BOLT	185	2	HC9-205-4	OUTPUT OILSEAL
86	1	WSH-010	DOWTY WASHER	186	2	CS-1671	OUTPUT FLANGES
87	1	LOCKING RING	LOCKING RING (PINION)	187	1	SPA-073	BEARING SPACER
89	1	ORI-001	O-RING	188	1	CS-1631	BEARING SPACER
91	1	ORI-203	O-RING	189	1	CS-1628-B	BEARING SPACER
93	1	NUT-005	KAYNUT	190	1	FTRE-260-9	PIVOT PIECE
94	2	HP-N-9006	SOCKET CAP SCREW	191	2	FTRE-260-9A	PIVOT PINS
95	2	NUT-007	KAYNUT	192	4	CIR-054	CIRCLIPS

# FTRE RATIO CONFIGURATION NOW OBSOLETE (USED IN 2008 ONLY)

## 6 SPEED PARTS LIST Continued (FTRE RATIOS ONLY)

FTR 6 SPEED ASSEMBLY USING FTRE RATIOS			
Position	QTY	Part Number	Description
193	1	FTRE-260-3A	RACK PLUG
194	5	BEA-395	NEEDLE ROLLERS
195	1	HP-M-9042	DOWTY WASHER
196	1	SPA-077	SENSOR SPACER
200	1	FTRE-237-1	REVERSE POST
201	1	WSH-089	WASHER
202	1	BEA-401	NEEDLE ROLLER
203	1	FTRE-237	REVERSE IDLER GEAR
204	1	SCR-129	SCREW
205	1	FTRE-237-2	BUSH
206	1	FTRE-237-4	INSERT
207	1	FTRE-201-1	PILLAR SPACER
208	1	FTRE-234-2	SPACER
209	1	FTRE-234-3	SPACER
210	1	FTRE-249	REVERSE FORK
211	1	FTR-212-ADJ	ADJUSTABLE DIFF ASSEMBLY
212	1	FTR-218-15	OUTPUT FLANGE
213	1	FTR-218-16	OUTPUT FLANGE
214	1	SCR-119	BI-HEX BOLT
215	2	FTR-213-9	TOP HAT BUSHES
216	2	FTR-213-11	TRIPOD INSERTS
217	1	NUT-004	KAYNUT

ILLUSTRATED PARTS LIST  
FOR 5 SPEED CONFIGURATIONS OF  
FTR, FTRS, JFR & LJS.  
(NOT INCLUDING FTRE RATIOS)



**CASINGS & ASSOCIATED PARTS- 5 SPEED  
(NOT SUITABLE FOR USE WITH FTRE RATIOS)**

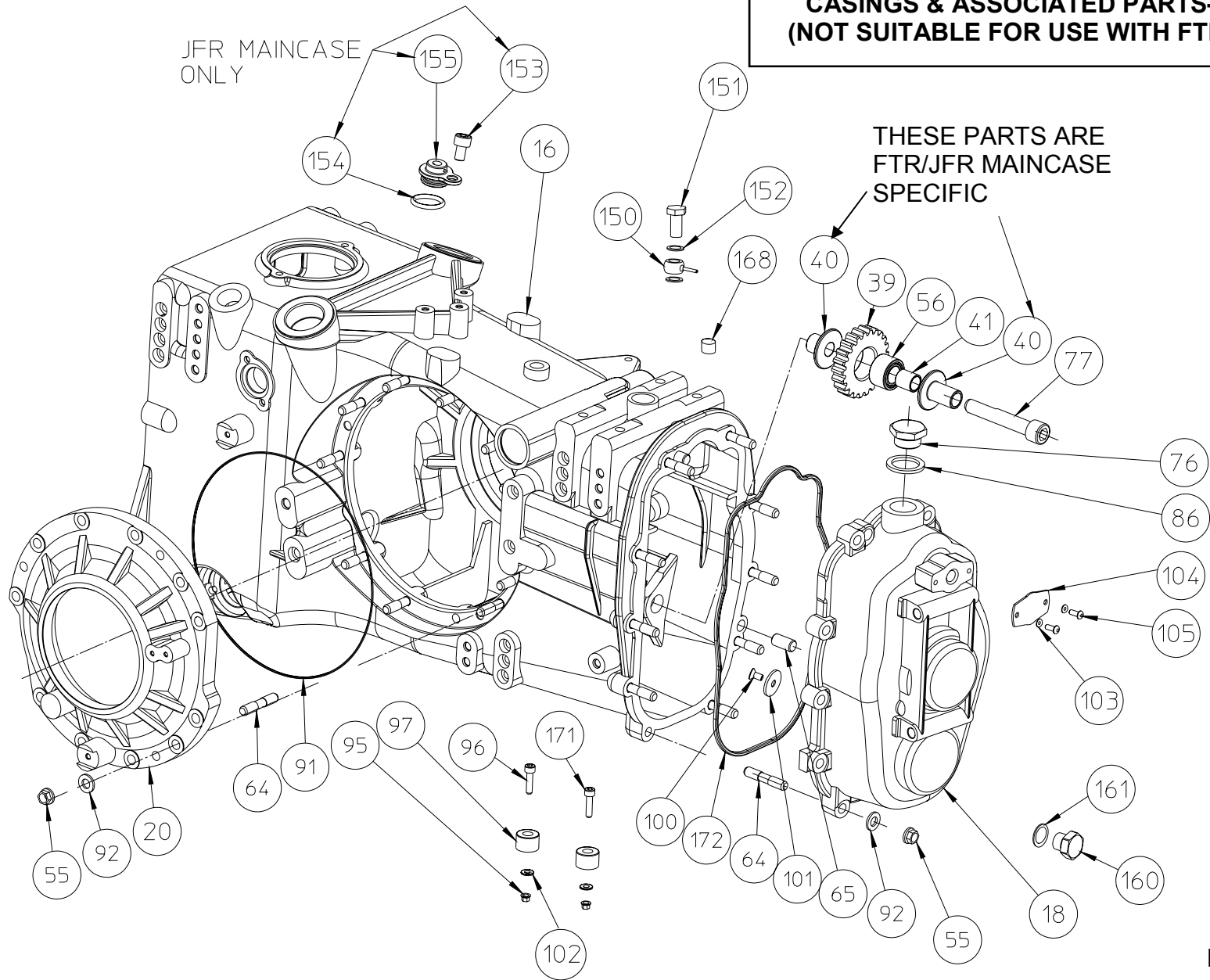

**Fig.18**

**LAYSHAFT ASSEMBLY—5 SPEED  
(NOT SUITABLE FOR USE WITH FTRE RATIOS)**

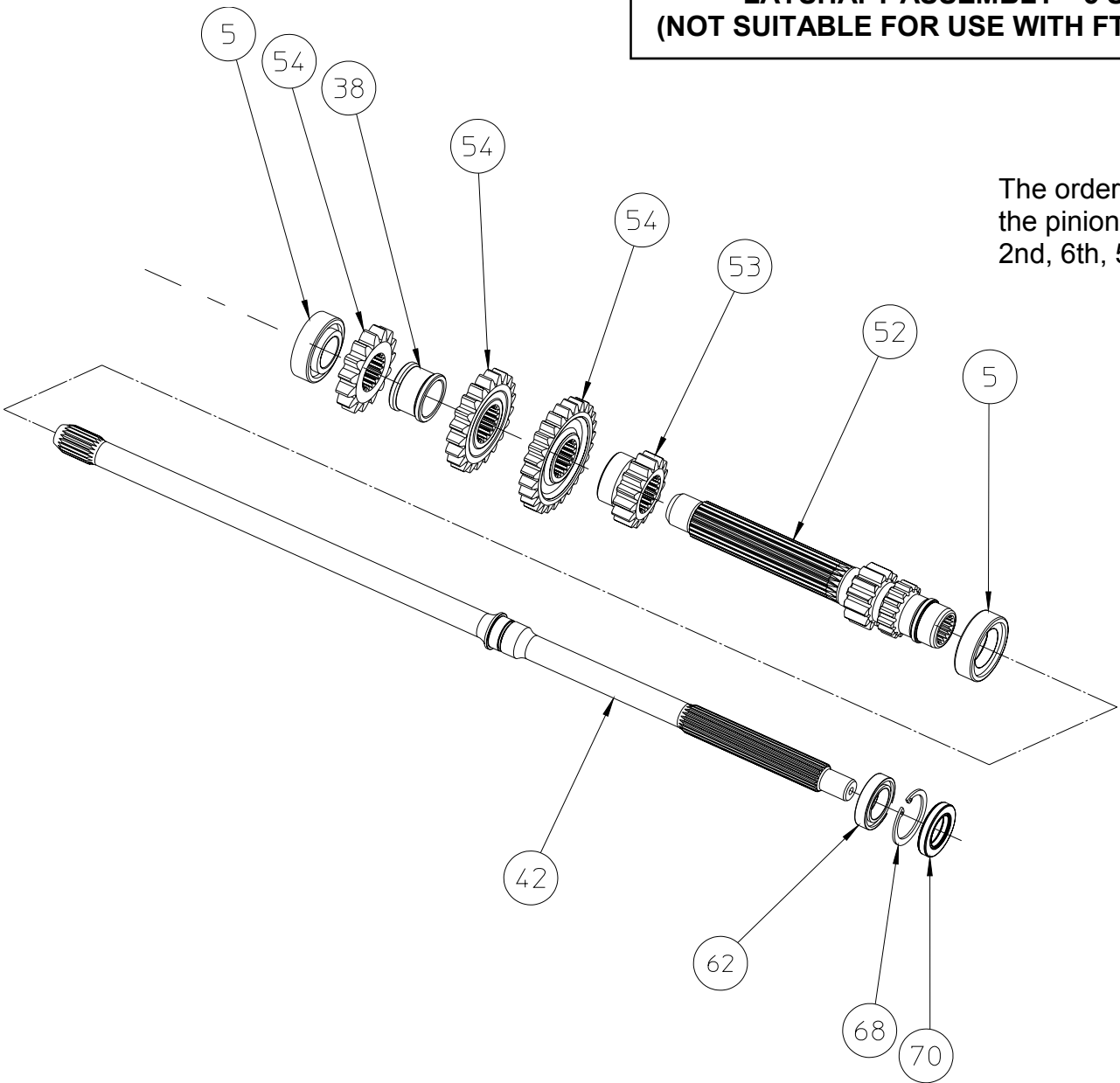

The order of the gear ratios from the pinion head end are 1st, 2nd, 6th, 5th, 4th and 3rd

**Fig.19**

**PINION SHAFT ASSEMBLY- 5 SPEED  
(NOT SUITABLE FOR USE WITH FTRE RATIOS)**

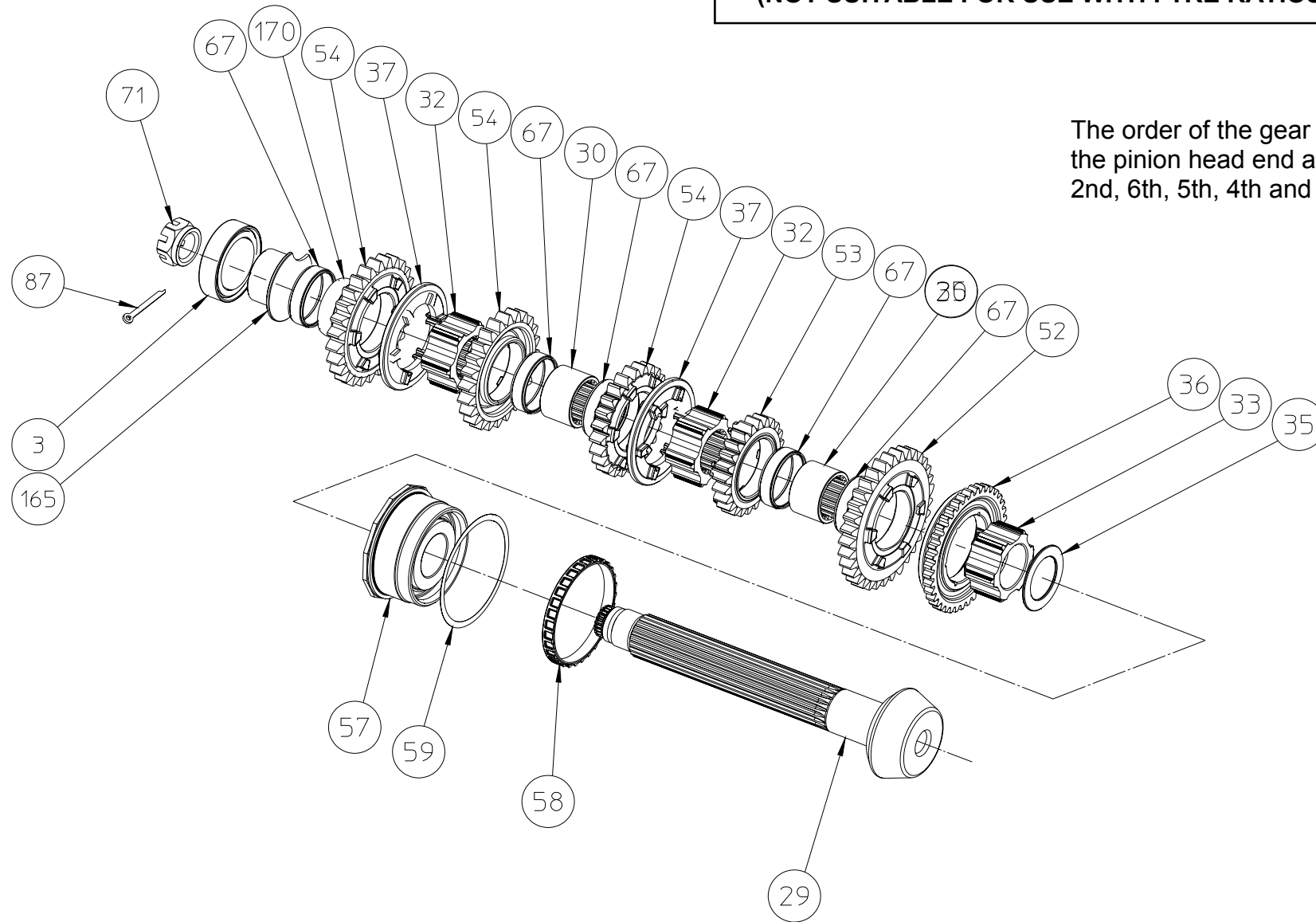

The order of the gear ratios from the pinion head end are 1st, 2nd, 6th, 5th, 4th and 3rd

**Fig.20**

**SELECTOR ASSEMBLY- 5 SPEED  
(NOT SUITABLE FOR USE WITH FTRE RATIOS)**

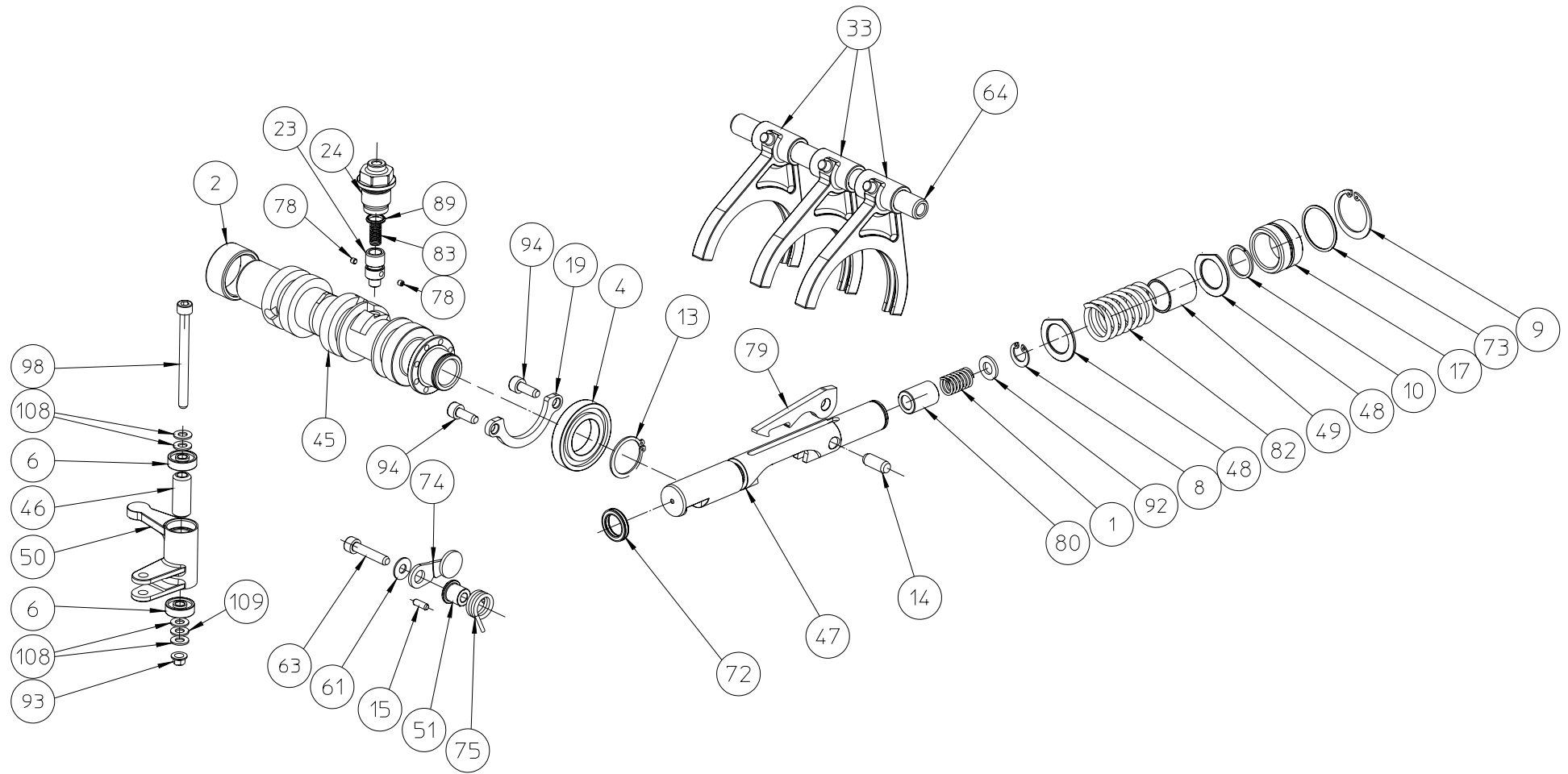

**Fig.21**

5 SPEED PARTS LIST (NOT SUITABLE FOR USE WITH FTRE RATIOS)

FTR/JFR 5 SPEED ASSEMBLY				FTR/JFR 5 SPEED ASSEMBLY			
Position	QTY	Part Number	Description	Position	QTY	Part Number	Description
1	1	102-260-9	COMPRESSION SPRING	28	2	FTR-218-3	BEARING RING
2	1	105-260-6	NEEDLE ROLLER BEARING	29	1	FINAL-DRIVE	FINAL DRIVE ASSY
3	1	BEA-002	ROLLER BEARING	30	2	FTR-225	BEARING INNER TRACK
4	1	BEA-141	BALL BEARING	31	2	FTR-226	BEARING INNER TRACK
5	2	BEA-159	ROLLER BEARING	32	3	FTR-227	HUB
6	2	BEA-162	BALL BEARING		3	FTRL-227	
7	2	BEA-171	TAPER ROLLER BEARING	33	1	FTR-228	REVERSE HUB
8	1	CIR-082	CIRCLIP	34	1	LD5-229-4	SPACER
9	1	CIR-083	CIRCLIP	35	1	FTR-229-1	FORK SETTING SPACER
10	1	CIR-084	CIRCLIP	36	1	FTR-231	REVERSE SLIDING GEAR
13	2	DGB-239-0	EXTERNAL CIRCLIP	37	3	FTR-232	CLUTCH RING
14	1	DOW-024	DOWEL	38	2	FTR-234-1	SPACER-INPUT SHAFT
15	1	F3A-202-9A	DOWEL		2	FTRL-234-1	
16	1	FTR-201 (FTR)	MAINCASE	39	1	FTR-237	REVERSE IDLER GEAR
	1	JFR-201 (JFR)			1	FTRL-237	
17	1	FTR-201-1	SELECTOR RACK STOP	40	1 (FTR), 1 (JFR)	JFR-237-1	REVERSE IDLER SPIGOT
18	1	BEARING-CARRIER	BEARING CARRIER				
19	1	FTR-202-2	BEARING RETAINING PLATE	40	1 (JFR)	FTR-237-1	REVERSE IDLER SPIGOT
20	1	FTR-205 (FTR)	SIDEPLATE	40	1 (FTR)	FTR-237-3	REVERSE IDLER SPIGOT
	1	JFR-205 (JFR)		41	1	FTR-237-2	SLEEVE
21	2	FTR-205-1	SIDEPLATE SHIM	42	1	FTR-239	CLUTCH SHAFT
22	2	FTR-205-2	SIDEPLATE SPACER	43	1	FTR-246	SELECTOR RAIL
23	1	FTR-210-35	PLUNGER	44	4	FTR-250	SELECTOR FORK
24	1	FTR-210-36	PLUG	45	1	FTR-260	SELECTOR BARREL ASSY
25	1	DIFFERENTIAL-ASSY	DIFF ASSY	46	1	FTR-260-2	SPACER TUBE
26	2	OUTPUT-FLANGE	OUTPUT FLANGE				

PARTS DESIGNATED "FTRL" ARE LIGHTENED ALTERNATIVES THAT CAN BE FITTED AS DIRECT REPLACEMENTS FOR STANDARD PARTS.

5 SPEED PARTS LIST Continued (NOT SUITABLE FOR USE WITH FTRE RATIOS)

FTR/JFR 5 SPEED ASSEMBLY				FTR/JFR 5 SPEED ASSEMBLY			
Position	QTY	Part Number	Description	Position	QTY	Part Number	Description
47	1	FTR-260-3	SELECTOR RACK	69	2	LIP-042	OIL SEAL
	1	FTRL-260-3		70	1	LIP-043	OIL SEAL
48	2	FTR-260-4	SELECTOR RACK WASHER	71	1	LOCK NUT	LOCK NUT (PIN.TAIL)
49	1	FTR-260-5	SLEEVE	72	1	ORI-085	QUAD-RING
50	1	FTR-260-7	BELL CRANK	73	1	ORI-097	O-RING
51	1	FTR-260-8	SPRING TRUNION	74	1	PCT-260-2	DRUM STOPPER
52	1	LJS-RATIO-INT	LAYSHAFT ASSEMBLY	75	1	PCT-260-3	COIL SPRING
				76	1	PLU-030	PLUG
53	1	FTR-RATIO-HUB	FTR HUBBED GEAR PAIR	77	1 (FTR)	SCR-117	SOCKET CAP SCREW
54	4	FTR-RATIO-STD	FTR STANDARD GEAR PAIR		1 (JFR)	SCR-225	
55	21	NUT-004	KAYNUT	78	2	SCR-121	SOCKET SET SCREW
56	1	HC-237-2	NEEDLE ROLLER BEARING	79	1	SPH1077-M3	PAWL
57	1	HC8-222-1HB OR LOW FRICTION	PINION HEAD BEARING	80	1	SPH1078-M3	PLUNGER
58	1 (FTR)	FGA-222-1A	NUT (BMW SPEC FTR ONLY)	81	2	FTR-260-10	BARREL SPACERS
	0 (JFR)			82	1	SPR-057	COMPRESSION SPRING
58	1	NUT-031	NUT (NOT BMW SPEC)	83	1	SPR-058	COMPRESSION SPRING
59	1	HC8-222-2	SHIM	85	8	CROWNWHEEL-BOLT	CROWNWHEEL BOLT
60	1 (FTR)	HC8-222-2A	WASHER (BMW FTR ONLY)	86	1	WSH-010	DOWTY WASHER
	0 (JFR)	HC8-222-2A		87	1	FT-230-1	SPLIT PIN
61	1	HP-M-7039	DRUM WASHER	89	1	ORI-001	O-RING
62	1	HP-M-8008	BALL BEARING	91	1 (FTR)	ORI-203	O-RING
63	1	HP-M-9054	SOCKET HEAD CAP SCREW		1 (JFR)	ORI-189	
64	21	STU-073	STUD	92	22	F3D-236-1	WASHER
65	2	LD-201-5	DOWEL	93	1	NUT-005	KAYNUT
67	6	LD-226-1	NEEDLE CAGE	94	2	HP-N-9006	SOCKET CAP SCREW
68	1	LD-244-10	CIRCLIP	95	2	NUT-007	KAYNUT

PARTS DESIGNATED "FTRL" ARE LIGHTENED ALTERNATIVES THAT CAN BE FITTED AS DIRECT REPLACEMENTS FOR STANDARD PARTS.

5 SPEED PARTS LIST Continued (NOT SUITABLE FOR USE WITH FTRE RATIOS)

FTR/JFR 5 SPEED ASSEMBLY			
Position	QTY	Part Number	Description
96	2	HC96-203-18	SOCKET CAP SCREW
97	2	VG-201-1A	MAGNET
98	1	HP-M-9008	SOCKET CAP SCREW
100	1	SCR-023	COUNTERSUNK SKT SCREW
101	1	WSH-051	WASHER
102	2	WSH-011	WASHER
103	2	WSH-069	PLAIN WASHER
104	1	TE-201-4	COVER PLATE
105	2	HP-M-9062	SKT BUTTON HEAD SCREW
106	2	HP-N-9004	WIRE CLIP
107	2	GAITOR-KIT (OPT)	GAITOR KIT
108	4	LD-202-9	WASHER
109	1	WSH-067	SHIM WASHER
160	1	HYD-026	BLANKING PLUG
161	1	400-868-4490-41	DOWTY WASHER
162	1	LD-205-2A	BEARING SPACER
163	2	LD-205-3	BALL BEARING
164	2	LJS-201-1	BEARING CARRIER
165	1	LJS-221-1	BEARING INNER TRACK
166	2	ORI-006	O-RING
168	1	SCR-097	SOCKET SET SCREW
169	2	FT-219-1A	CIRCLIP
170	1	FTR-225	BEARING INNER TRACK
172	1	VG-201-9	SEALING STRIP

PARTS DESIGNATED "FTRL" ARE LIGHTENED ALTERNATIVES THAT CAN BE FITTED AS DIRECT REPLACEMENTS FOR STANDARD PARTS.

**5 SPEED VARIABLE PARTS**

VARIABLE  
PARTS

ITEM No	DESCRIPTION	PART No	QTY	QTY
29	FINAL DRIVE	LJS-221-12:34	1	1
25	DIFF ASSY	LJS-212-F	1	1
85	C/WHEEL BOLT	VG-221-1B	8	8
16	MAINCASE	FTR-201	1	
		JFR-201		1
20	SIDEPLATE	FTR-205	1	
		JFR-205		1
42	CLUTCHSHAFT	FTR-239	1	
		JFR-239		1
40	REVERSE IDLER BUSH	FTR-237-3	1	
		FTR-237-1		1
91	SIDEPLATE O-RING	ORI-203	1	
		ORI-189		1
77	REVERSE IDLER SCREW	SCR-117	1	
		SCR-225		1
18	BEARING CARRIER	JFR-202-A	1	
		JFR-202		1
167	ACCESS PLUG ASSY	PLU-059-A	N/A	1

FTR MAINCASE  
 FREE DIFF 12:34 CWP  
 CRASH BOX (DALLARA)  
 JFR MAINCASE  
 FREE DIFF 12:34 CWP



JFR ONLY			
Position	QTY	Part Number	
150	1	HP-M-9037	BANJO JOINTS
151	1	HP-M-9039	BANJO BOLT
152	2	HP-M-9038	SEALING WASHER
153	1	SCR-048	SOCKET HEAD SCREW
154	1	ORI-080	O-RING
155	1	PLU-059	PLUG

FTRS SPEC ONLY			
Position	QTY	Part Number	
16	1	FTRS-201	MAINCASE
20	1	FTRS-205	SIDEPLATE
64	11	STU-036	STUD
SEE BELOW	2	SCR-218	SOCKET HEAD SCREW
SEE BELOW	2	ORI-037	O-RING

BMW SPEC ONLY			
Position	QTY	Part Number	
50	1	663-6-120	RHS ONLY
52	1	7772376	LAYSHAFT RATIO 12:38
53	1	7772377	GEAR RATIO HUB 15:32
53	1	7772378	GEAR RATIO HUB 15:33
54	1	7772379	GEAR RATIO 15:25
54	1	7772380	GEAR RATIO 16:23
54	1	7772381	GEAR RATIO 17:26
54	1	7772382	GEAR RATIO 17:30
54	1	7772383	GEAR RATIO 18:19
54	1	7772384	GEAR RATIO 18:27
54	1	7772385	GEAR RATIO 18:24
54	1	7772386	GEAR RATIO 18:25
54	1	7772387	GEAR RATIO 19:21
54	1	7772388	GEAR RATIO 21:24
54	1	7772389	GEAR RATIO 21:25
54	1	7772390	GEAR RATIO 21:26
54	1	7772393	GEAR RATIO 19:23

FTRS Edition additional parts layout

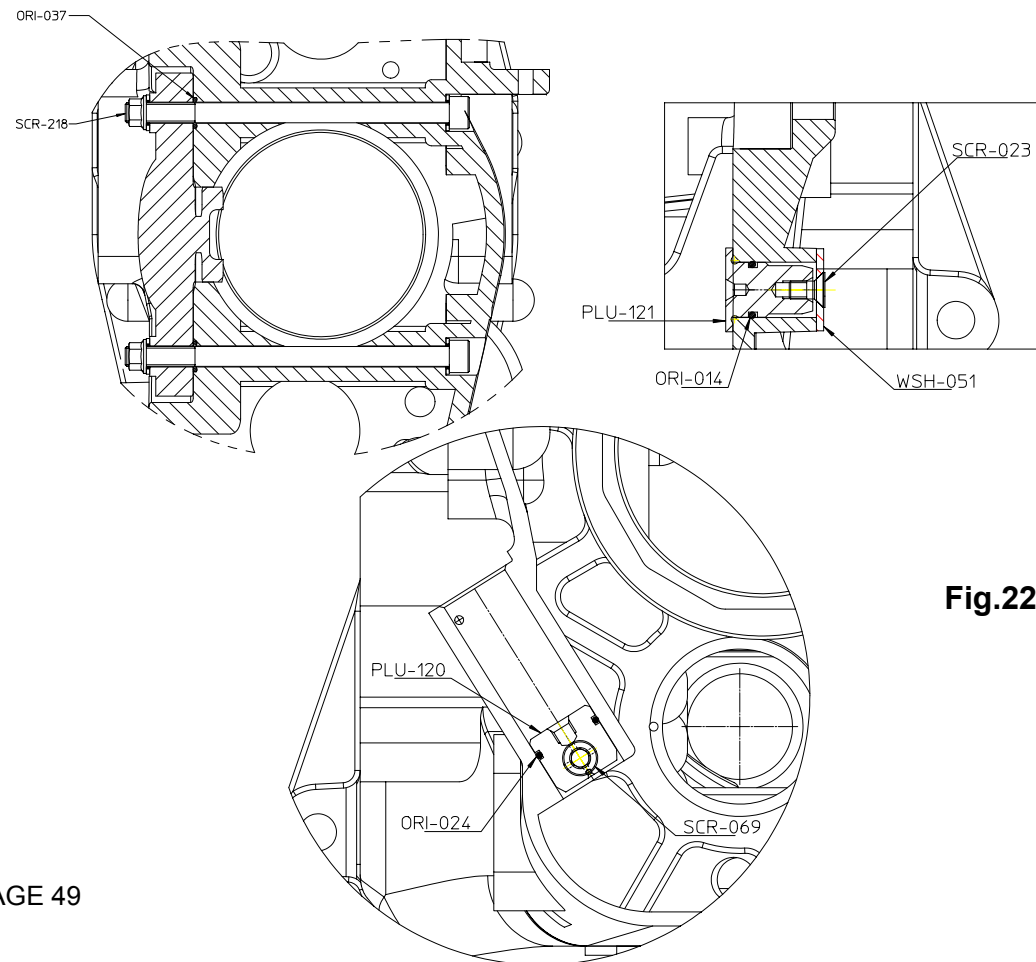
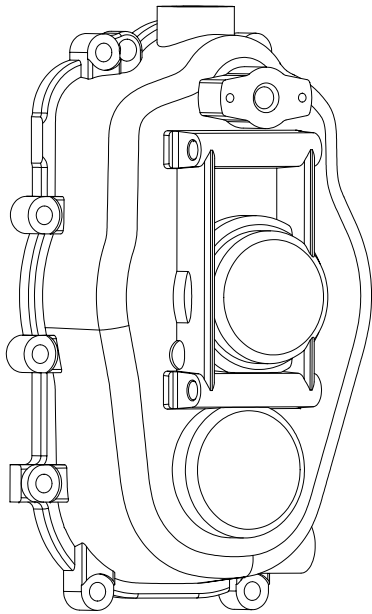
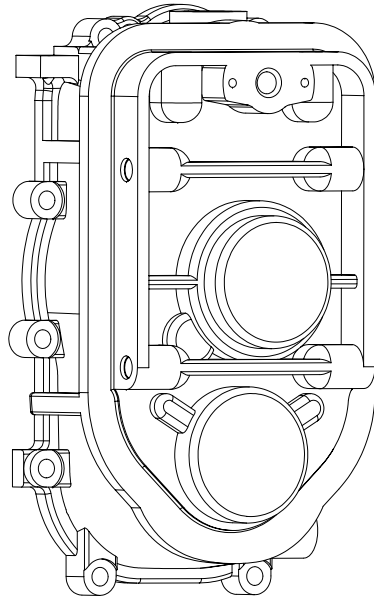

Fig.22

**BEARING CARRIER OPTIONS**



**JFR-202  
5 SPEED WITHOUT  
CRASH BOX FIXING**



**JFR-202-A  
5 SPEED WITH CRASH  
BOX FIXING**

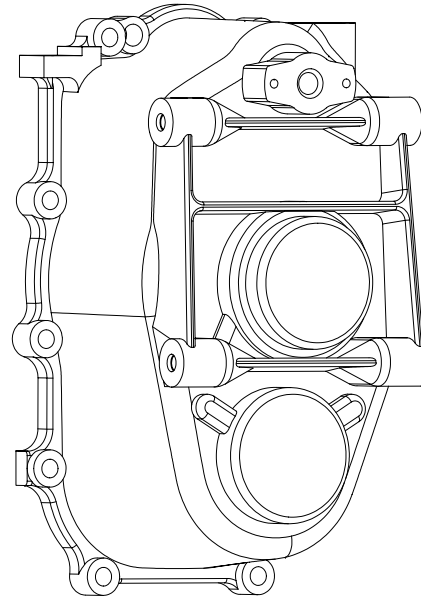

**FTR-202  
6 SPEED WITHOUT  
CRASH BOX FIXING**

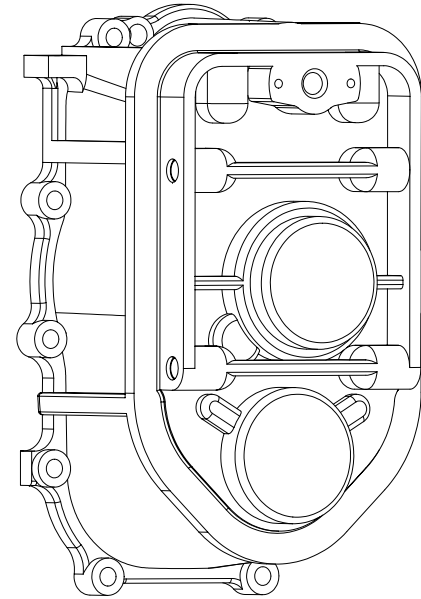

**FTR-202-A  
6 SPEED WITH CRASH  
BOX FIXING**

**Fig.23**

# ILLUSTRATED PARTS LIST FOR DIFFERENTIAL CONFIGURATIONS

TRIPOD DIFFERENTIAL ASSEMBLY

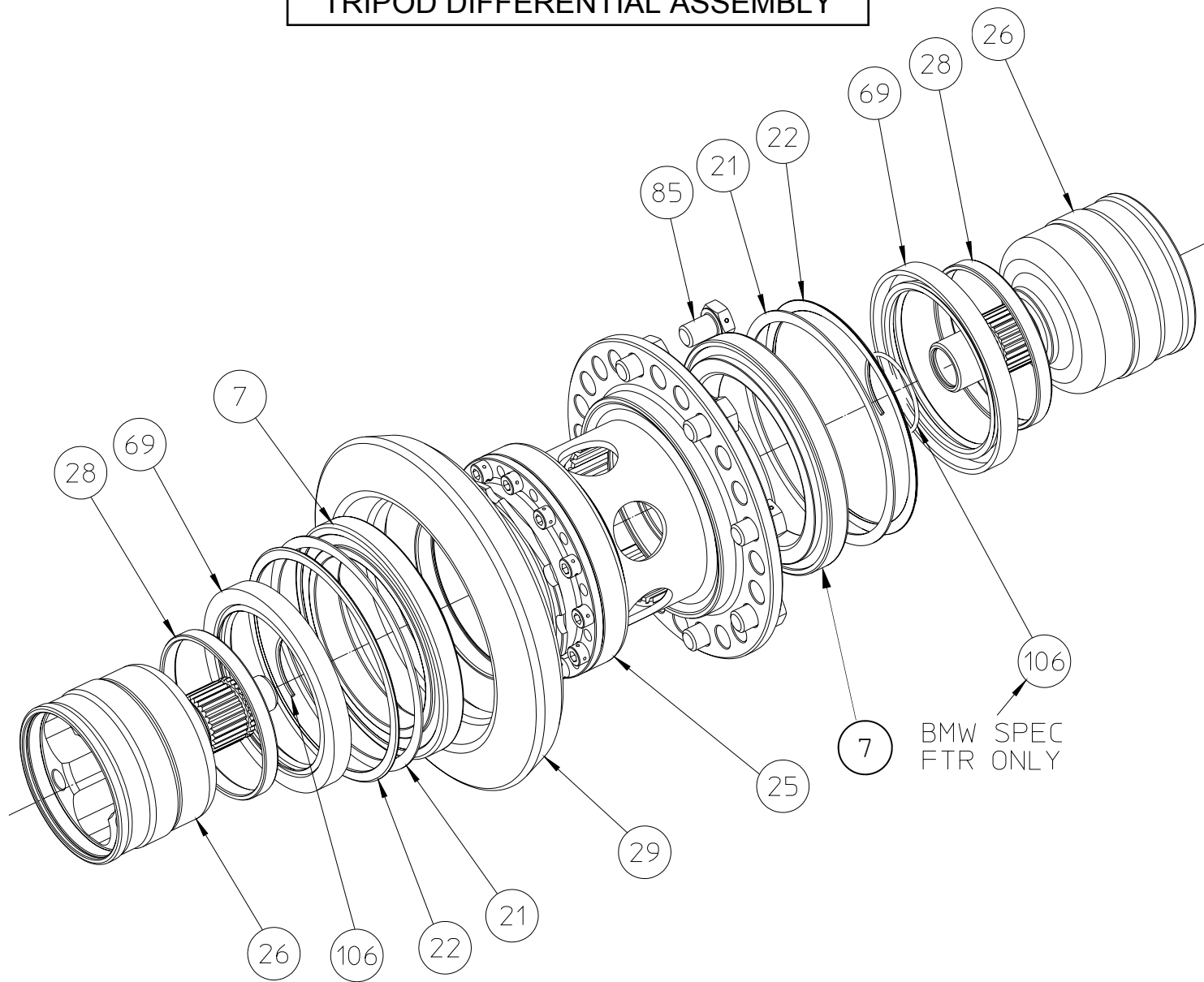
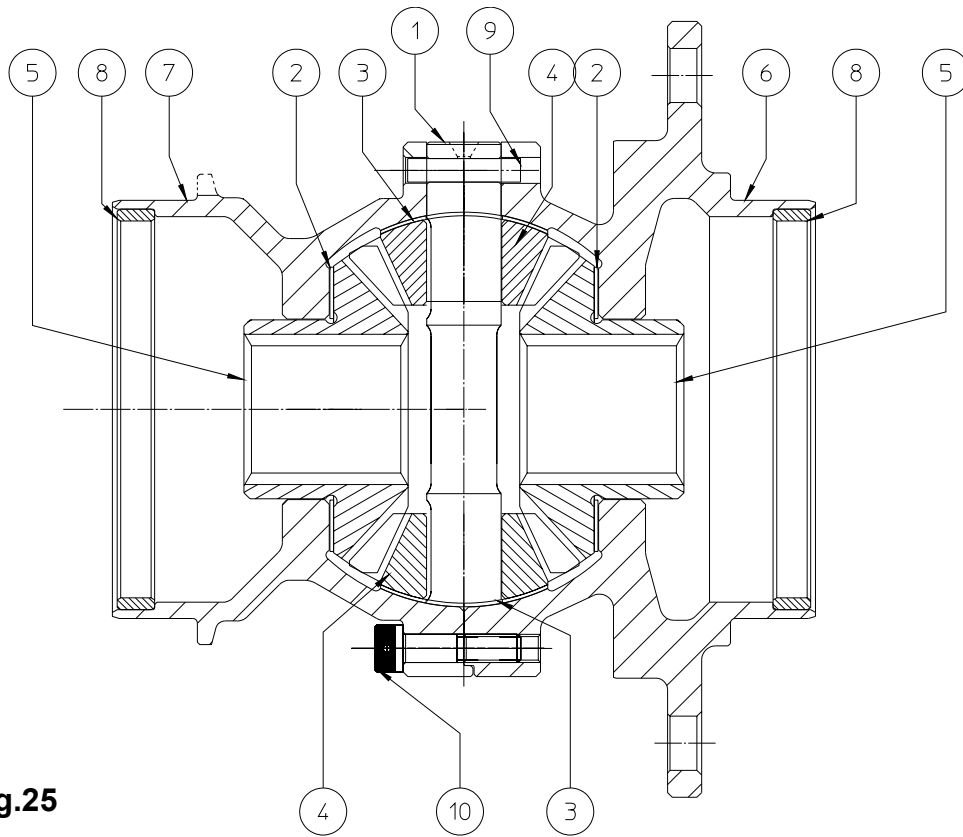

Fig.24



**Fig.25**

**FTR-212-FD FREE DIFFERENTIAL ASSEMBLY AS USED IN STAR MAZDA SPECIFICATION**

Bill of Material FTR-212-FD FREE DIFFERENTIAL ASSY			
Position	Qty	PartNo	PartName
1	1	FTR-213-16FD	CROSS SHAFT
2	2	FTR-213-18FD	SIDE BEVEL THRUST WASHER
3	2	FTR-213-19FD	PLANET BEVEL THRUST WASHER
4	2	FTR-213-5FD	PLANET BEVEL GEAR
5	2	FTR-213-6FD	SIDE BEVEL GEAR
6	1	FTR-213-A	DIFF CASE
7	1	FTR-213-B	DIFF CAP
8	2	FTR-218-3	BEARING RING
9	1	HP-M-9041	ROLL PIN
10	8	SCR-082	SOCKET CAP SCREW

ADDITIONAL PARTS REQUIRED TO UTILISE 4 PLANET GEARS		
Qty	PartNo	PartName
-1	FTR-213-16FD	CROSS SHAFT
1	FTR-213-15FD	PLANET SPIDER
2	FTR-213-19FD	PLANET BEVEL THRUST WASHER
2	FTR-213-5FD	PLANET BEVEL GEAR
-1	HP-M-9041	ROLL PIN

CASING					
FTR			JFR		
Position #	Part No	Description	Part No	Description	
7	BEA-171	TAPER ROLLER BEARING	BEA-171	TAPER ROLLER BEARING	
20	FTR-205	SIDEPLATE	JFR-205	SIDEPLATE	
21	FTR-205-1	SIDEPLATE SHIM	FTR-205-1	SIDEPLATE SHIM	
22	FTR-205-2	SIDEPLATE SPACER	FTR-205-2	SIDEPLATE SPACER	
69	LIP-042	LIPSEAL	LIP-042	LIPSEAL	
91	ORI-203	O-RING	ORI-189	O-RING	

# REFER TO PAGES 25-27,37-39 (6sp) OR 45-47 (5sp) for other part numbers

There is a Gaitor kit option with these tripods, see Gaitor Assembly page

**OUTPUT TRIPODS AVAILABLE**  
FTR-218-FD

BEA-171 CAN BE REPLACED WITH LOW FRICTION BEARING BEA-408

## FTR-212 LIMITED SLIP DIFFERENTIAL

Position	Qty	PartNo	PartName
1	4	FTC-213-10	CLUTCH PLATE
2	1	FTC-213-3	SPACER-PRELOAD SETTING
3	3	FTC-213-5AF	PLANET BEVEL GEAR
4	2	FTC-213-7	SIDE GEAR RINGS
5	6	FTC-213-8	CORE PLATE
6	1	FTR-213	DIFF CASE
7	2	FTR-213-6F	SIDE BEVEL GEAR
8	1	FTR-214	DIFF END CAP
9	12	SGT-244-13	SOCKET CAP SCREW

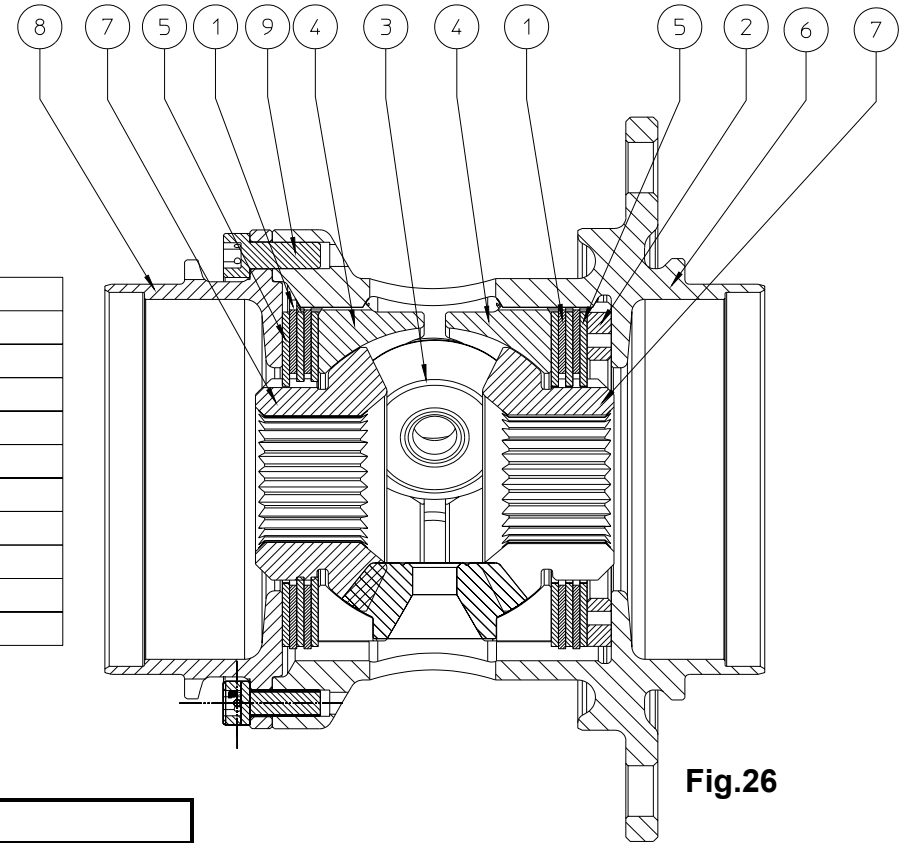

**Fig.26**

CASING				
FTR			JFR	
Position #	Part No	Description	Part No	Description
7	BEA-171	TAPER ROLLER BEARING	BEA-171	TAPER ROLLER BEARING
20	FTR-205	SIDEPLATE	JFR-205	SIDEPLATE
21	FTR-205-1	SIDEPLATE SHIM	FTR-205-1	SIDEPLATE SHIM
22	FTR-205-2	SIDEPLATE SPACER	FTR-205-2	SIDEPLATE SPACER
69	LIP-042	LIPSEAL	LIP-042	LIPSEAL
91	ORI-203	O-RING	ORI-189	O-RING

# REFER TO PAGES 25-27,37-39(6sp) OR 45-47(5sp) for other part numbers

BEA-171 CAN BE REPLACED WITH LOW FRICTION BEARING BEA-408

### OUTPUT TRIPODS AVAILABLE

FTR-218-8  
FTR-218-1AS  
FTR-218-7AS  
FTR-218-2  
FTRL-218-3  
FTRL-218-4

There is a Gaitor kit option with these tripods, see Gaitor Assembly page

**FTRL-212 DIFFERENTIAL ASSEMBLY  
AS USED IN DALLARA F3 2005  
SPECIFICATION**

Bill of Material	FTRL-212	LIGHT DIFFERENTIAL ASSY	
Position	Qty	PartNo	PartName
1	4	FTC-213-10	CLUTCH PLATE
2	1	FTC-213-3	SPACER-PRELOAD SETTING
3	3	FTC-213-5AF	PLANET BEVEL GEAR
4	2	FTC-213-7	SIDE GEAR RINGS
5	6	FTC-213-8	CORE PLATE
6	2	FTR-213-6F	SIDE BEVEL GEAR
7	1	FTRL-213	LIGHT DIFF CASE
8	1	FTRL-214	LIGHT DIFF END CAP
9	12	SGT-244-13	SOCKET CAP SCREW

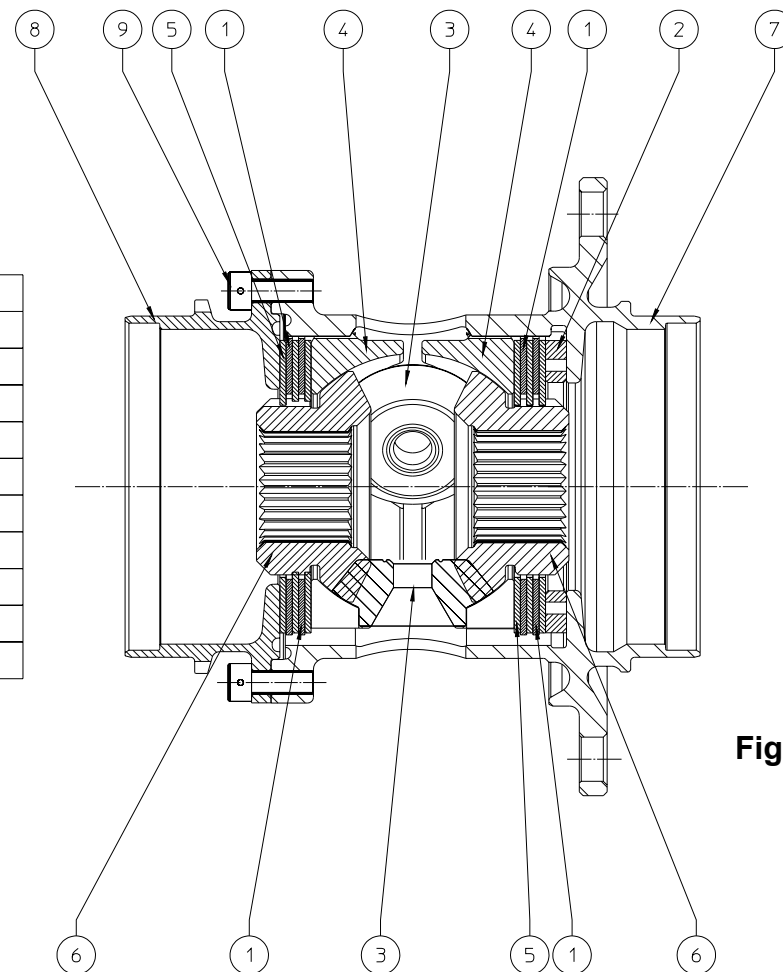

**Fig.27**

CASING				
FTR		JFR		
Position #	SIDEPLATE ARRANGEMENT		SIDEPLATE ARRANGEMENT	
	Part No	Description	Part No	Description
7	BEA-171	TAPER ROLLER BEARING	BEA-171	TAPER ROLLER BEARING
20	FTR-205	SIDEPLATE	JFR-205	SIDEPLATE
21	FTR-205-1	SIDEPLATE SHIM	FTR-205-1	SIDEPLATE SHIM
22	FTR-205-2	SIDEPLATE SPACER	FTR-205-2	SIDEPLATE SPACER
69	LIP-042	LIPSEAL	LIP-042	LIPSEAL
91	ORI-203	O-RING	ORI-189	O-RING

# REFER TO PAGES 25-27,37-39(6sp) OR 45-47(5sp) for other part numbers

BEA-171 CAN BE REPLACED WITH  
LOW FRICTION BEARING BEA-408

**OUTPUT TRIPODS  
AVAILABLE**

- FTRL-218-1C
- FTRL-218-2C
- FTRL-218-3
- FTRL-218-4

There is a Gaitor kit option with these tripods, see Gaitor Assembly page

FTR-212-ADJ  
PRELOAD ADJUSTABLE DIFFERENTIAL ASSEMBLY WITH TRIPODS

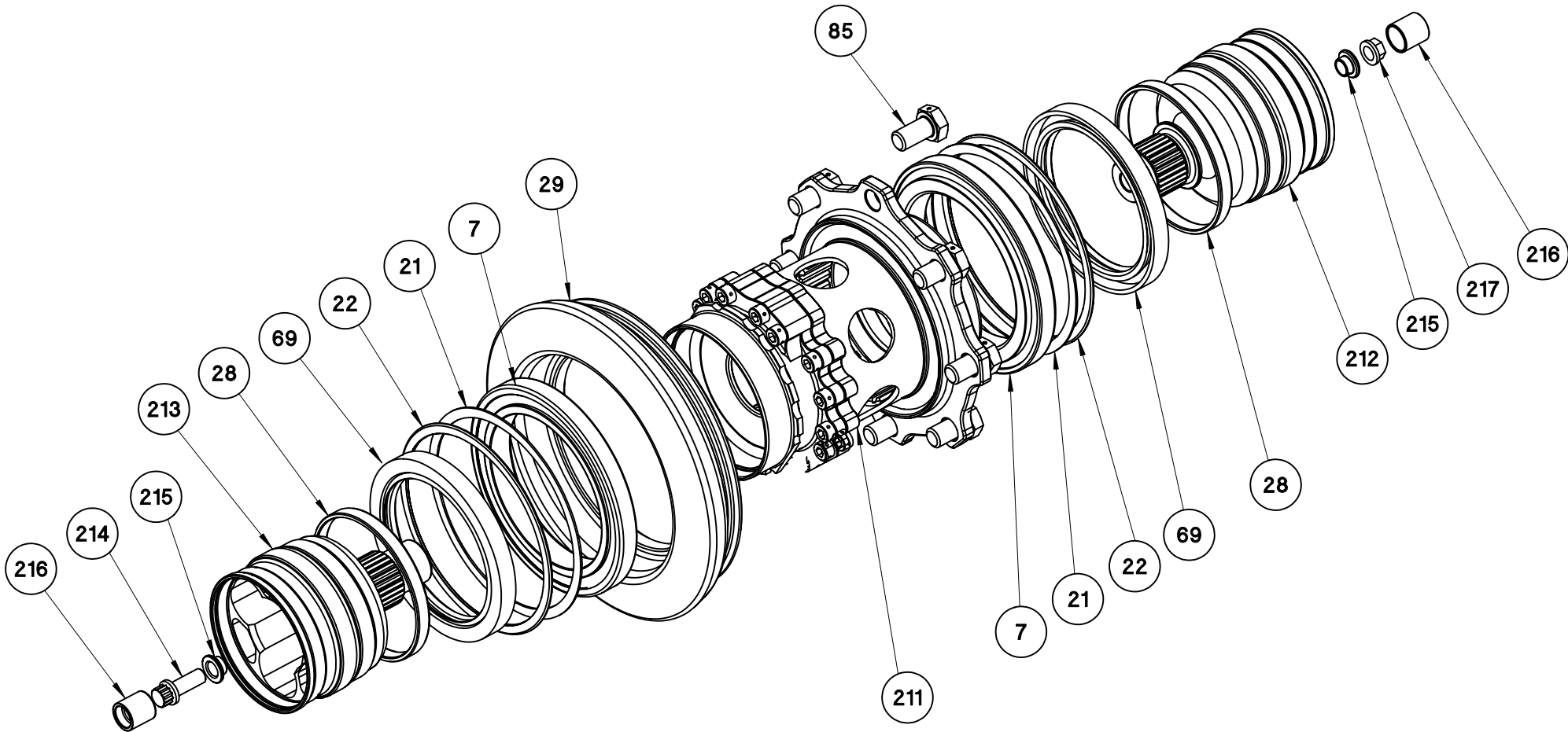

Fig.28



# FTR-212-ADJ ADJUSTABLE DIFFERENTIAL ASSEMBLY

Bill of Material	FTR-212-ADJ	DIFFERENTIAL ASSY	
Position	Qty	PartNo	PartName
1	1	BEA-399	BUSH
2	1	CST-213-2A	ADJUSTER WHEEL
3	4	FTC-213-10	CLUTCH PLATE
4	1	FTC-213-3	SPACER-PRELOAD SETTING
5	6	FTC-213-8	CORE PLATE
6	1	FTR-213-10	CARRIER
7	1	FTR-213-15	SPIDER
8	3	FTR-213-5F	PLANET BEVEL GEAR
9	2	FTR-213-6F	SIDE BEVEL GEAR
10	2	FTR-213-7	SIDE GEAR RINGS
11	1	FTR-213-8	DIFF CASE
12	1	FTR-214-1	DIFF END CAP
13	2	FTR-218-3	BEARING RING
14	1	HSI-213-8C	WORM SCREW
15	15	SGT-244-13	SOCKET CAP SCREW
16	1	SPR-120	DISK SPRING
17	3	SCR-068	SOCKET CAP SCREW
18	1	FTR-213-20	DETENT PIN
19	1	SPR-119	COMPRESSION SPRING

CASING				
		FTR	JFR	
Position #	Part No	Description	Part No	Description
7	BEA-171	TAPER ROLLER BEARING	BEA-171	TAPER ROLLER BEARING
20	FTR-205	SIDEPLATE	JFR-205	SIDEPLATE
21	FTR-205-1	SIDEPLATE SHIM	FTR-205-1	SIDEPLATE SHIM
22	FTR-205-2	SIDEPLATE SPACER	FTR-205-2	SIDEPLATE SPACER
69	LIP-042	LIPSEAL	LIP-042	LIPSEAL
91	ORI-203	O-RING	ORI-189	O-RING
214	SCR-119	BI-HEX BOLT	SCR-119	BI-HEX BOLT
215	FTR-213-9	TOP HAT BUSHES	FTR-213-9	TOP HAT BUSHES
216	FTR-213-11	TRIPOD INSERTS	FTR-213-11	TRIPOD INSERTS
217	NUT-004	KAYNUT	NUT-004	KAYNUT

# REFER TO PAGES 25-27, 37-39 (6sp) OR 45-47 (5sp) for other part numbers

ALTERNATE PART BEA-075

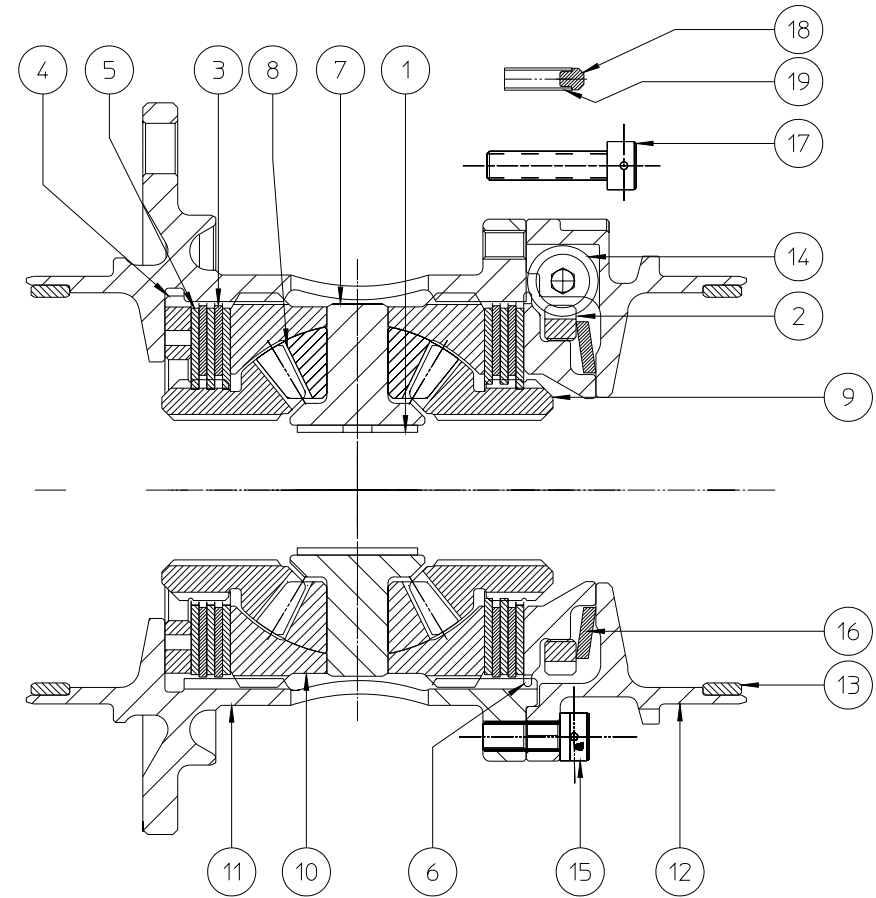

**Fig.29**

BEA-171 CAN BE REPLACED WITH LOW FRICTION BEARING BEA-408

OUTPUT TRIPODS AVAILABLE
FTR-218-15
FTR-218-16
FTRE-218-LAS
FTRE-218-RAS

There is a Gaitor kit option with these tripods, see Gaitor Assembly page

FLANGED ALTERNATIVE DIFFERENTIAL ASSEMBLY

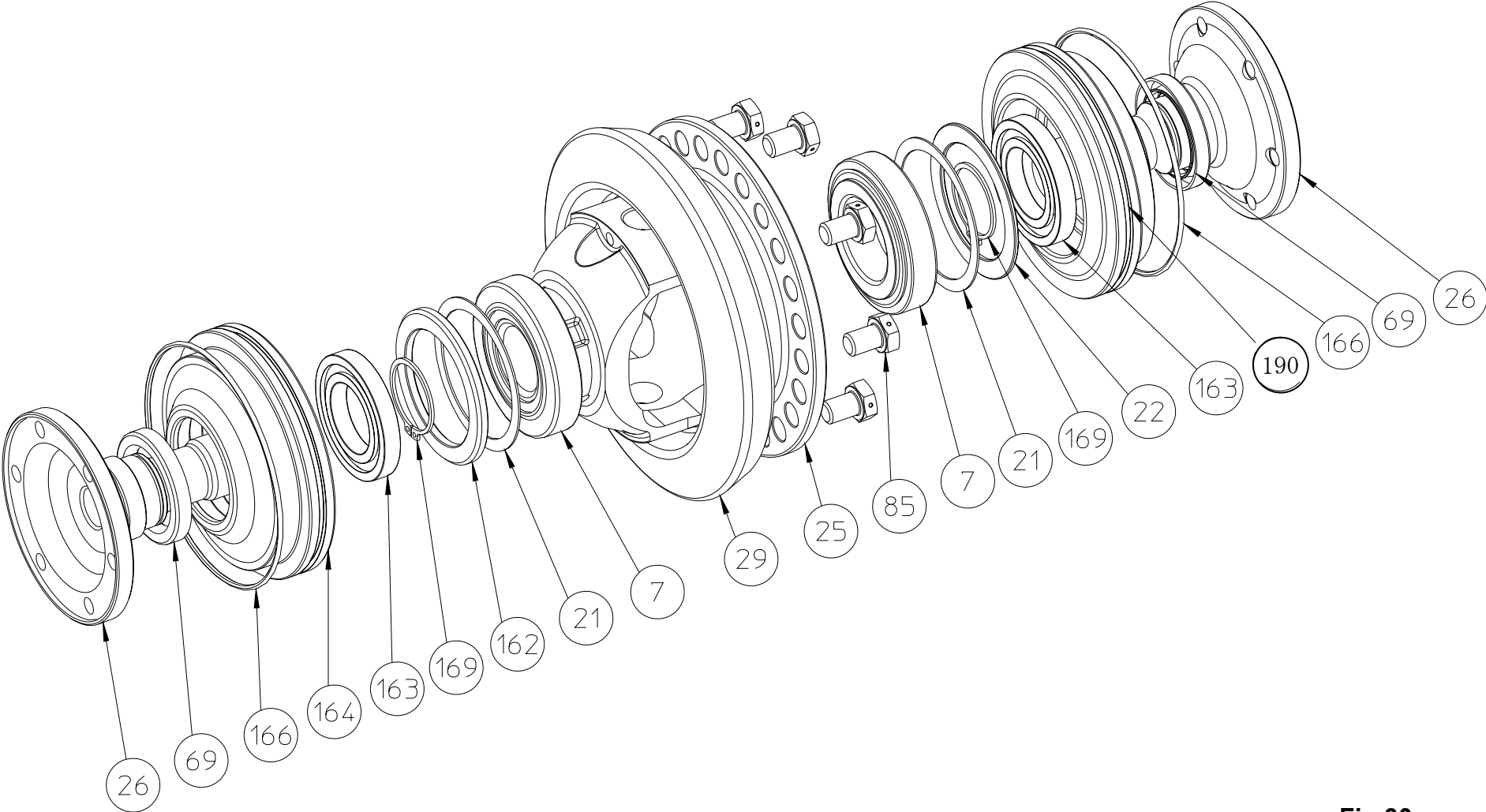
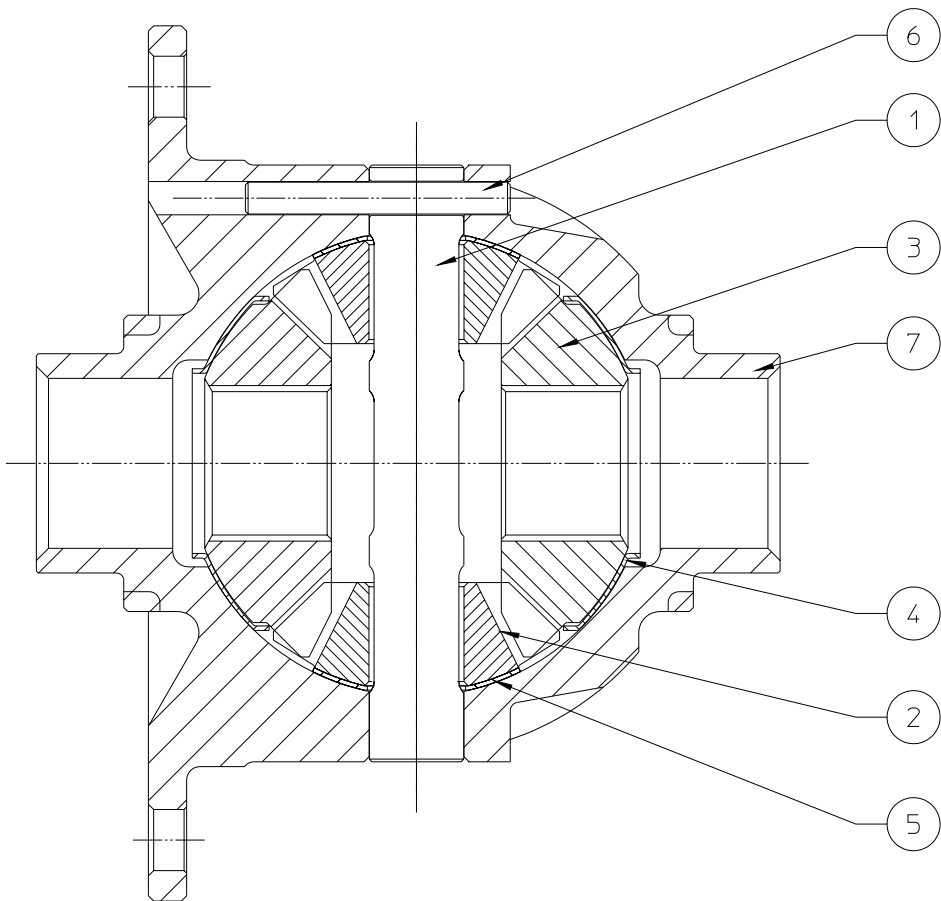

Fig.30



### LJS-212-F FREE DIFFERENTIAL

Bill of Material	LJS-212-F	LJS FREE DIFFERENTIAL	
Position	Qty	PartNo	PartName
1	1	HC8-214-2R	CROSS SHAFT
2	2	HC8-214-3R	PLANET BEVEL
3	2	HC8-214-4R	SIDE BEVEL
4	2	HC8-214-5R	SIDE BEVEL WASHER
5	2	HC8-214-6R	PLANET BEVEL WASHER
6	1	HC8-214-7R	ROLL PIN
7	1	LJS-213-F	FREE DIFF CASE

OUTPUT FLANGES AVAILABLE
LJS-218
LD-218-LH x2

Fig.31

Position #	CASING			
	FTR		JFR	
	SIDEPLATE ARRANGEMENT		SIDEPLATE ARRANGEMENT	
	Part No	Description	Part No	Description
7	HC9-205-1	BEARING	HC9-205-1	BEARING
20	FTR-205	SIDEPLATE	JFR-205	SIDEPLATE
21	HC9-206-1	SHIM	HC9-206-1	SHIM
22	LD-205-2	SPACER	LD-205-2	SPACER
69	LD-205-4	OILSEAL	LD-205-4	OILSEAL
91	ORI-203	O-RING	ORI-189	O-RING
162	LD-205-2A	LH BEARING SPACER	LD-205-2A	LH BEARING SPACER
163	LD-205-3	BALL BEARING	LD-205-3	BALL BEARING
164	LJS-201-1	BEARING CARRIER	LJS-201-1	BEARING CARRIER
166	ORI-006	O-RING	ORI-006	O-RING
169	FT-219-1A	CIRCLIP	FT-219-1A	CIRCLIP
190	LJS-201-1	BEARING CARRIER	LJS-201-1	BEARING CARRIER

# REFER TO PAGES 25-27, 37-39 (6sp) OR 45-47 (5sp) for other part numbers

**LD-212 LIMITED SLIP DIFFERENTIAL**

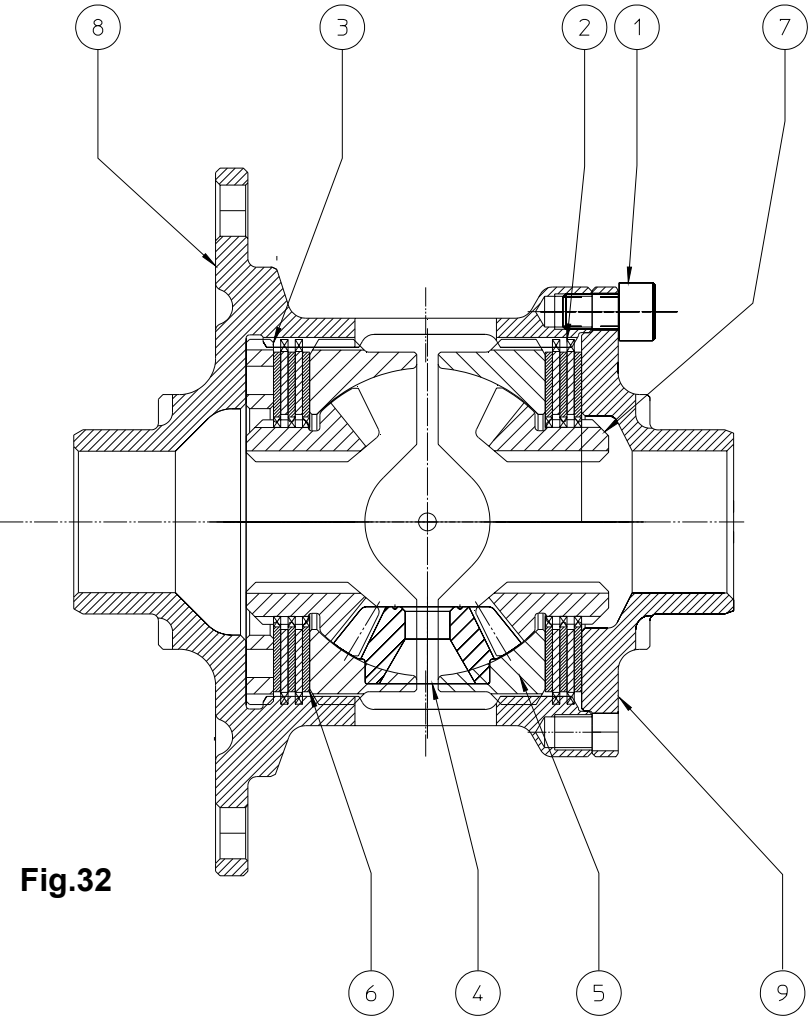

**Fig.32**

<b>OUTPUT FLANGES AVAILABLE</b>
LJS-218
LD-218-LH x2

Bill of Material		LD-212	LD DIFF ASSEMBLY
Position	Qty	PartNo	PartName
1	8	F3A-213-12	SOCKET CAP SCREW
2	4	FTC-213-10	CLUTCH PLATE
3	1	FTC-213-3	SPACER-PRELOAD SETTING
4	3	FTC-213-5AF	PLANET BEVEL GEAR
5	1	FTC-213-7	SIDE GEAR RINGS
6	6	FTC-213-8	CORE PLATE
7	2	HCC-213-6AF	SIDE BEVEL GEAR
8	1	LD-213	DIFFERENTIAL CASING
9	1	LD-214	END PLATE

<b>CASING</b>				
		<b>FTR</b>	<b>JFR</b>	
<b>Position #</b>	<b>SIDEPLATE ARRANGEMENT</b>		<b>SIDEPLATE ARRANGEMENT</b>	
	<b>Part No</b>	<b>Description</b>	<b>Part No</b>	<b>Description</b>
7	HC9-205-1	BEARING	HC9-205-1	BEARING
20	FTR-205	SIDEPLATE	JFR-205	SIDEPLATE
21	HC9-206-1	SHIM	HC9-206-1	SHIM
22	LD-205-2	LH BEARING SPACER	LD-205-2	LH BEARING SPACER
69	LD-205-4	OILSEAL	LD-205-4	OILSEAL
91	ORI-203	O-RING	ORI-189	O-RING
162	CS-1706-C	SPACER	CS-1706-C	SPACER
163	LD-205-3	BALL BEARING	LD-205-3	BALL BEARING
164	CS-1706-B	BEARING CARRIER	CS-1706-B	BEARING CARRIER
166	ORI-006	O-RING	ORI-006	O-RING
169	FT-219-1A	CIRCLIP	FT-219-1A	CIRCLIP
190	CS-1706-A	BEARING CARRIER	CS-1706-A	BEARING CARRIER

# REFER TO PAGES 25-27, 37-39 (6sp) OR 45-47 (5sp) for other part numbers

## LD-212-CP CAM & PAWL DIFFERENTIAL

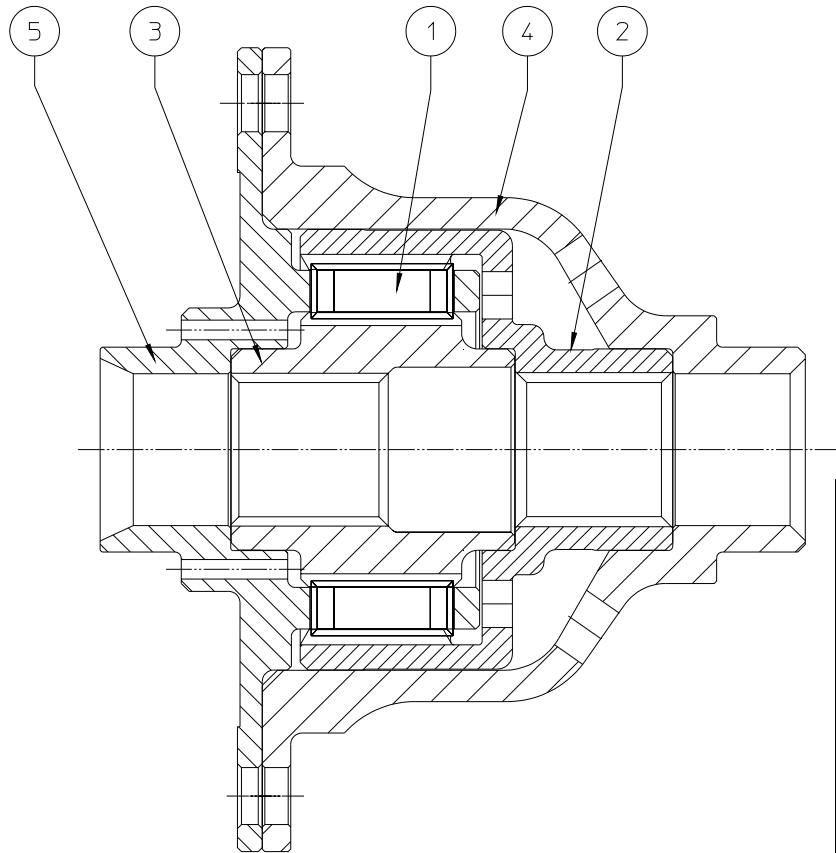

Bill of Material		LD-212-CP	CAM&PAWL DIFFERENTIAL
Position	Qty	PartNo	PartName
1	8	FT-217	PLUNGER
2	1	HC8-215	OUTER CAM TRACK
3	1	HC8-216	INNER CAM TRACK
4	1	SK-2383-A	DIFF CASE C & P
5	1	SK-2383-B	PLUNGER CARRIER

**Fig.33**

OUTPUT FLANGES AVAILABLE
LJS-218
LD-218-LH x2

CASING				
		FTR	JFR	
Position #	SIDEPLATE ARRANGEMENT		SIDEPLATE ARRANGEMENT	
	Part No	Description	Part No	Description
7	HC9-205-1	BEARING	HC9-205-1	BEARING
20	FTR-205	SIDEPLATE	JFR-205	SIDEPLATE
21	HC9-206-1	SHIM	HC9-206-1	SHIM
22	LD-205-2	SPACER	LD-205-2	SPACER
69	LD-205-4	OILSEAL	LD-205-4	OILSEAL
91	ORI-203	O-RING	ORI-189	O-RING
162	LD-206-2 AND HC9-205-2B	LH BEARING SPACERS	LD-206-2 AND HC9-205-2B	LH BEARING SPACERS
163	LD-205-3	BALL BEARING	LD-205-3	BALL BEARING
164	CS-1706-B	BEARING CARRIER	CS-1706-B	BEARING CARRIER
166	ORI-006	O-RING	ORI-006	O-RING
169	FT-219-1A	CIRCLIP	FT-219-1A	CIRCLIP
190	CS-1706-A	BEARING CARRIER	CS-1706-A	BEARING CARRIER

# REFER TO PAGES 25-27, 37-39(6sp) OR 45-47(5sp) for other



**LJS-212-F FREE DIFFERENTIAL FOR INBOARD BRAKE DISCS**

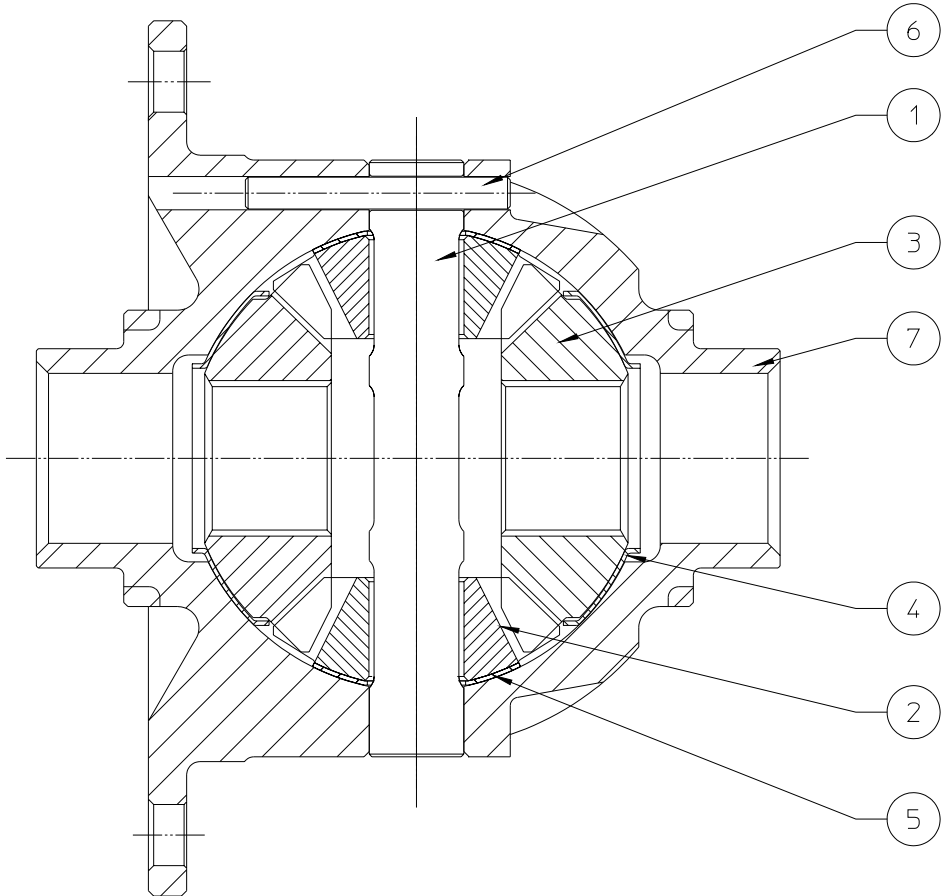

**OUTPUT FLANGES  
AVAILABLE**  
CS-1721

Bill of Material	LJS-212-F	LJS FREE DIFFERENTIAL	
Position	Qty	PartNo	PartName
1	1	HC8-214-2R	CROSS SHAFT
2	2	HC8-214-3R	PLANET BEVEL
3	2	HC8-214-4R	SIDE BEVEL
4	2	HC8-214-5R	SIDE BEVEL WASHER
5	2	HC8-214-6R	PLANET BEVEL WASHER
6	1	HC8-214-7R	ROLL PIN
7	1	LJS-213-F	FREE DIFF CASE

CASING				
		FTR	JFR	
Position #	SIDEPLATE ARRANGEMENT		SIDEPLATE ARRANGEMENT	
	Part No	Description	Part No	Description
7	HC9-205-1	BEARING	HC9-205-1	BEARING
20	FTR-205	SIDEPLATE	JFR-205	SIDEPLATE
21	HC9-206-1	SHIM	HC9-206-1	SHIM
91	ORI-203	O-RING	ORI-189	O-RING
166	ORI-006	O-RING	ORI-006	O-RING
169	FT-219-1A	CIRCLIP	FT-219-1A	CIRCLIP
183	HC9-205-3	BALL BEARING	HC9-205-3	BALL BEARING
184	CS-1628	BEARING CARRIER	CS-1628	SBEARING CARRIER
185	HC9-205-4	OILSEAL	HC9-205-4	OILSEAL
188	CS-1731	LH BEARING SPACER	CS-1731	LH BEARING SPACER
189	CS-1628-B	SPACER	CS-1628-B	SPACER

# REFER TO PAGES 25-27, 37-39 (6sp) OR 45-47 (5sp) for other part numbers

**Fig.35**

FLANGED LIMITED SLIP DIFFERENTIAL ASSEMBLY SUITABLE FOR INBOARD BRAKE DISCS

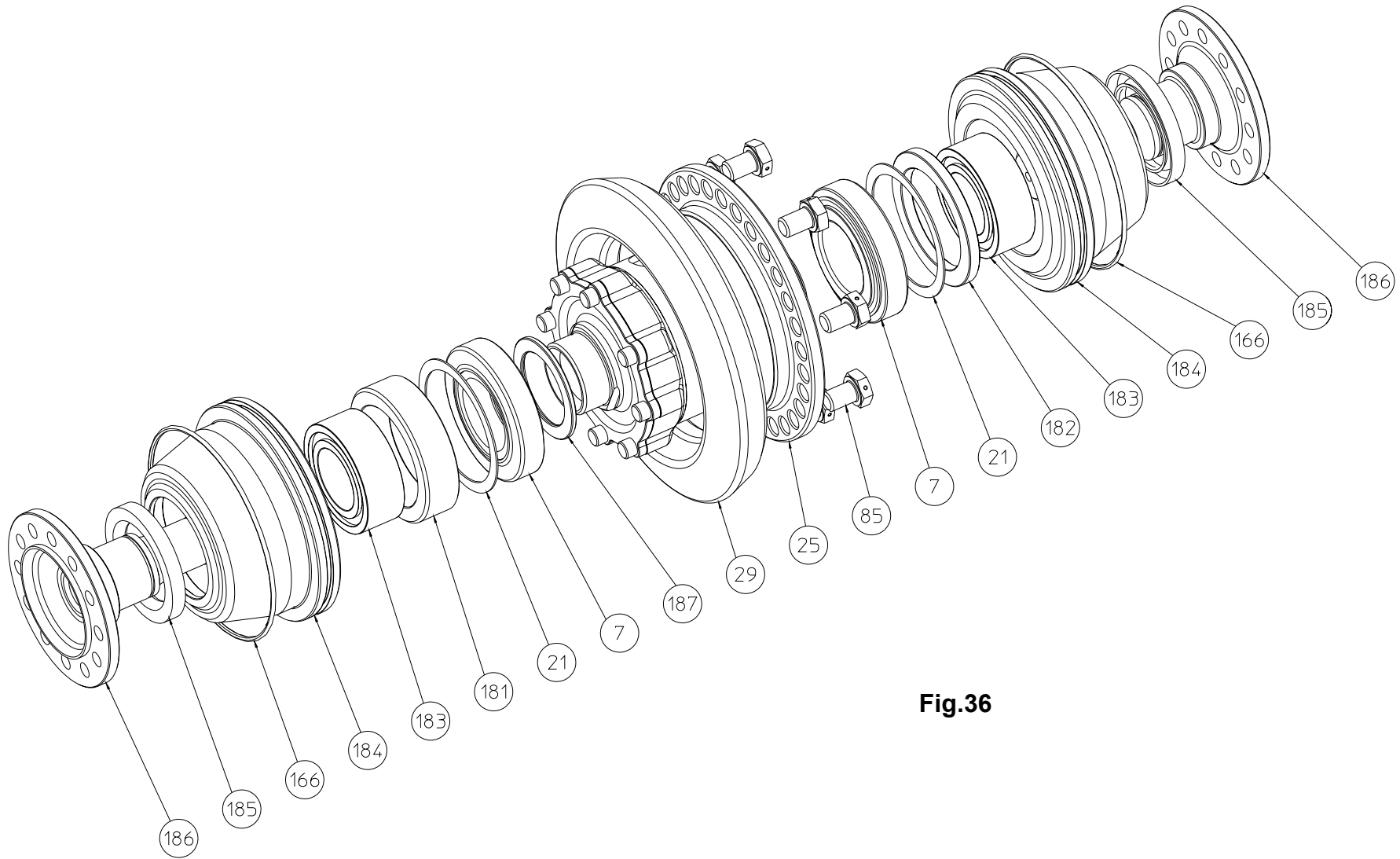
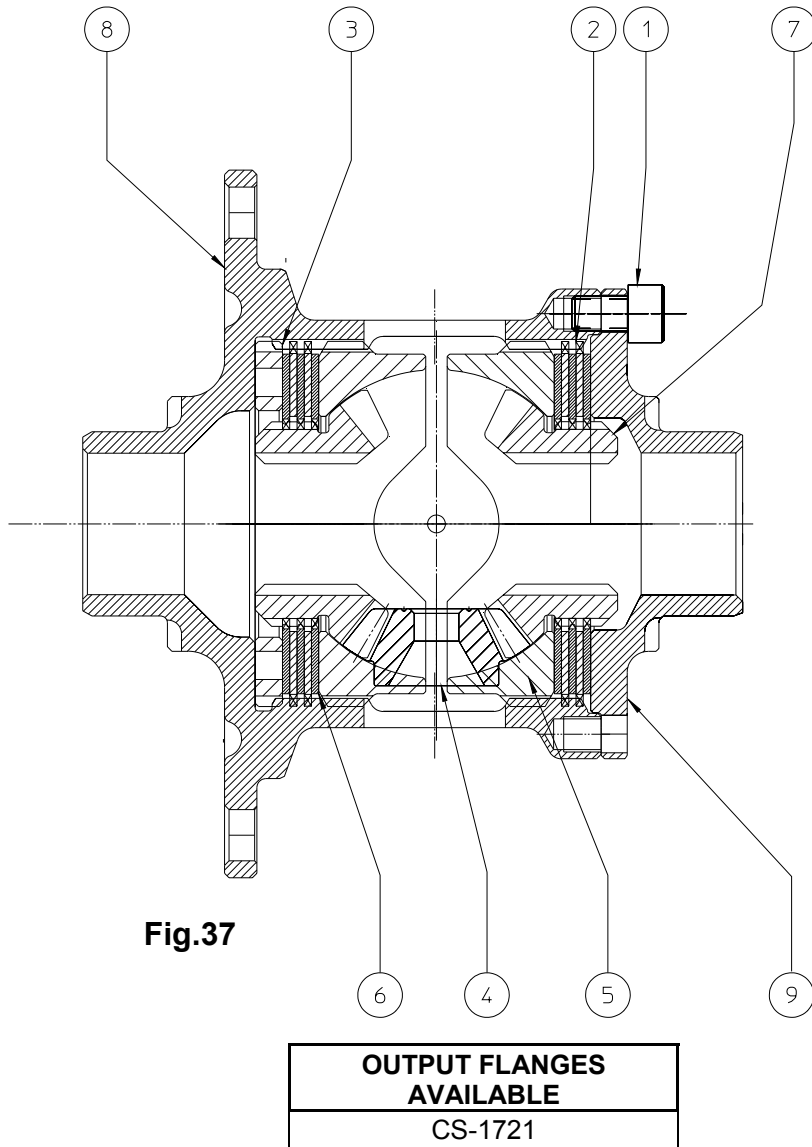

Fig.36



## LD-212 LIMITED SLIP DIFFERENTIAL FOR INBOARD BRAKE DISCS



**Fig.37**

Bill of Material		LD-212	LD DIFF ASSEMBLY
Position	Qty	PartNo	PartName
1	8	F3A-213-12	SOCKET CAP SCREW
2	4	FTC-213-10	CLUTCH PLATE
3	1	FTC-213-3	SPACER-PRELOAD SETTING
4	3	FTC-213-5AF	PLANET BEVEL GEAR
5	1	FTC-213-7	SIDE GEAR RINGS
6	6	FTC-213-8	CORE PLATE
7	2	HCC-213-6AF	SIDE BEVEL GEAR
8	1	LD-213	DIFFERENTIAL CASING
9	1	LD-214	END PLATE

Position #	CASING			
	FTR		JFR	
	SIDEPLATE ARRANGEMENT		SIDEPLATE ARRANGEMENT	
	Part No	Description	Part No	Description
7	HC9-205-1	BEARING	HC9-205-1	BEARING
20	FTR-205	SIDEPLATE	JFR-205	SIDEPLATE
21	HC9-206-1	SHIM	HC9-206-1	SHIM
91	ORI-203	O-RING	ORI-189	O-RING
166	ORI-006	O-RING	ORI-006	O-RING
169	FT-219-1A	CIRCLIP	FT-219-1A	CIRCLIP
181	FTR-205-4	LH BEARING SPACER	FTR-205-4	LH BEARING SPACER
182	FTR-205-3	SPACER	FTR-205-3	SPACER
183	HC9-205-3	BALL BEARING	HC9-205-3	BALL BEARING
184	CS-1628	BEARING CARRIER	CS-1628	SBEARING CARRIER
185	HC9-205-4	OILSEAL	HC9-205-4	OILSEAL
187	SPA-073	SPACER	SPA-073	SPACER

# REFER TO PAGES 25-27,37-39(6sp) OR 45-47(5sp) for other part numbers

**RAMP ORIENTATION**

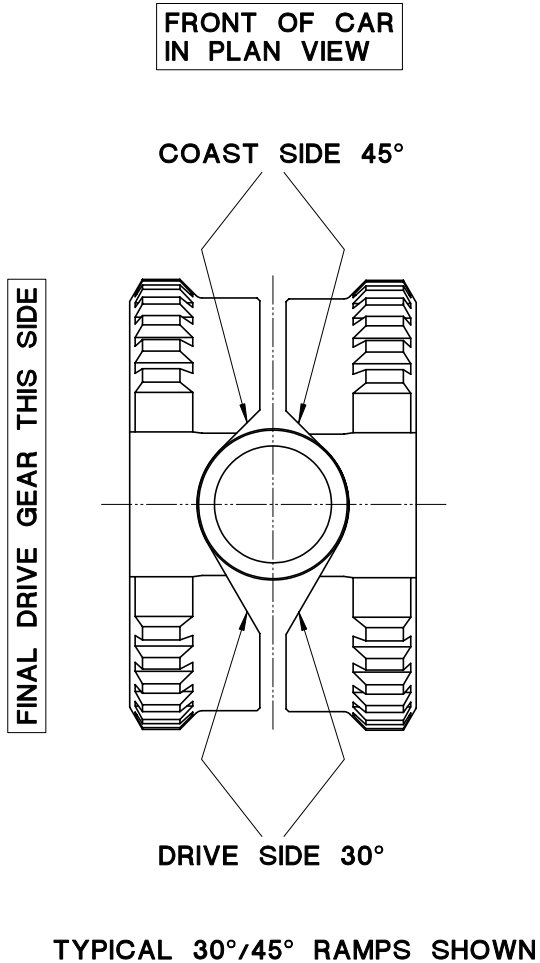

**Fig.38**

**FTR GAITOR ASSEMBLY**

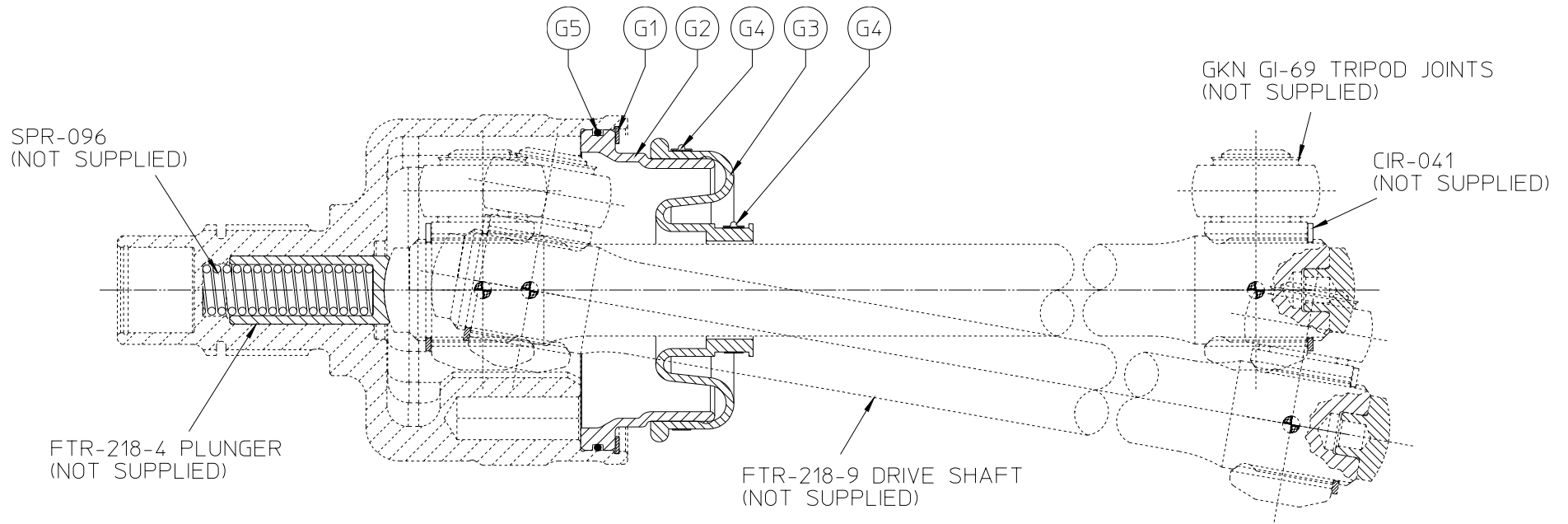

Bill of Material		FTR-218-6	FTR GAITOR ASSY
Position	Qty	PartNo	PartName
G1	1	CIR-089	SPIRAL CIRCLIP
G2	1	FTR-218-6A	GAITOR FLANGE
G3	1	GTR-004	TRIPOID GAITOR
G4	2	GTR-008	GAITOR CLIP
G5	1	ORI-099	O'RING

**Fig.39**

# FTRE AND FTRL LIGHTWEIGHT TRIPOD ASSEMBLIES (FTRE-218-LAS, FTRE-218 RAS, FTRL-218-LAS, FTRL-218-RAS)

Bill of Material		FTRE-218-LAS	TRIPOD JOINT ASSY
Position	Qty	PartNo	PartName
L1	1	FTRE-218-2	TRIPOD JOINT OUTER
L2	1	FTRE-218-3	TRIPOD SEALING RING
L3	1	FTRE-218-4	GAITOR FLANGE
L4	2	ORI-120	O-RING
L5	3	SCR-175	SOCKET CAP SCREW

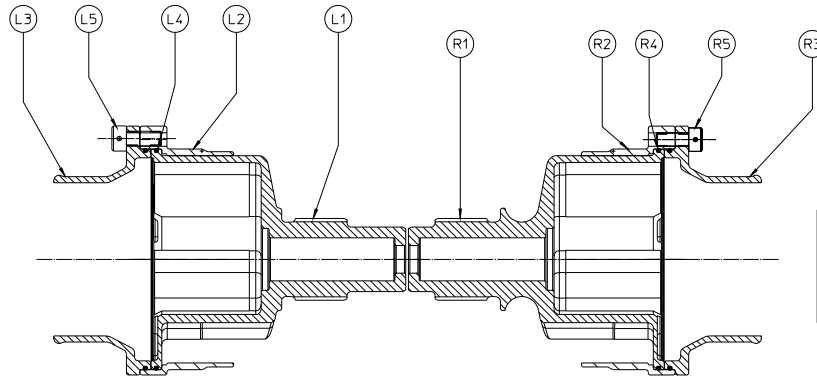

Bill of Material		FTRE-218-RAS	TRIPOD JOINT ASSY
Position	Qty	PartNo	PartName
R1	1	FTRE-218-1	TRIPOD JOINT OUTER
R2	1	FTRE-218-3	TRIPOD SEALING RING
R3	1	FTRE-218-4	GAITOR FLANGE
R4	2	ORI-120	O-RING
R5	3	SCR-175	SOCKET CAP SCREW

Bill of Material		FTRL-218-LAS	TRIPOD JOINT ASSY
Position	Qty	PartNo	PartName
L1	1	FTRE-218-3	TRIPOD SEALING RING
L2	1	FTRE-218-4	GAITOR FLANGE
L3	1	FTRL-218-3AS	OUTPUT FLANGE ASSY
L4	2	ORI-120	O-RING
L5	3	SCR-175	SOCKET CAP SCREW

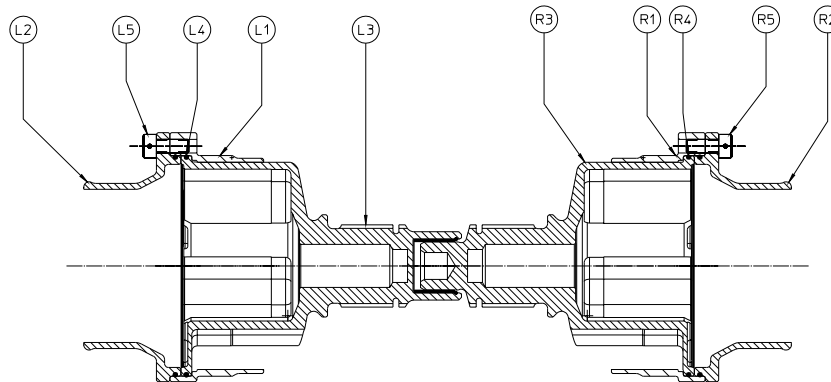

Bill of Material		FTRL-218-RAS	TRIPOD JOINT ASSY
Position	Qty	PartNo	PartName
R1	1	FTRE-218-3	TRIPOD SEALING RING
R2	1	FTRE-218-4	GAITOR FLANGE
R3	1	FTRL-218-4	TRIPOD JOINT OUTER
R4	2	ORI-120	O-RING
R5	3	SCR-175	SOCKET CAP SCREW

**Fig.40**

**GEARBOX TOOLING**

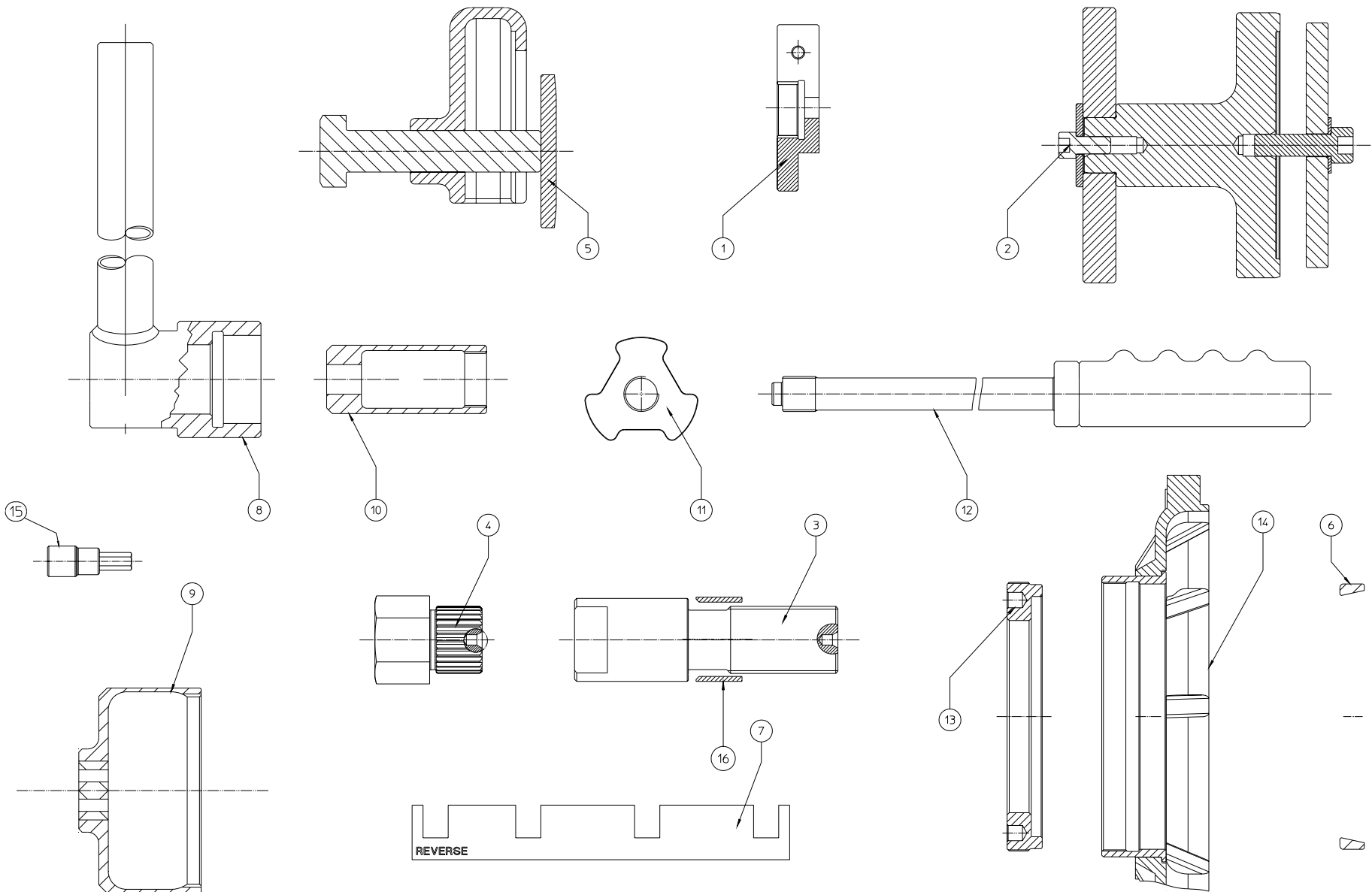

**Fig.41**

## TOOLING PARTS LIST

<b>TOOLING</b>			
<b>Item No.</b>	<b>Qty</b>	<b>Stock Code</b>	<b>Description</b>
1	1	SK-1913-A	PINION SETTING TOOL
2	1	SK-1709	PINION SETTING JIG
	1	SK-2192	PINION SETTING JIG (LJS ONLY)
3	1	SK-1710-A	DIFF HOLDING POST
4	1	SK-1710-B	DIFF PRE-LOAD TOOL
5	1	SK-1714	BEARING PULLER
6	1	SK-1715	DUMMY OUTER RACE
7	1	SK-1716	COMB TOOL
8	1	SK-1427	REACTION BAR
9	1	SK-247	TYPE 3 PINION SPANNER
10	1	SK-1175-C	SOCKET
11	1	SK-2025	FTR TRIPOD REMOVAL TOOL
12	1	SK-2025-A	SLIDE HAMMER KIT
13	1	SK-1718-A	DUMMY SIDEPLATE CAP
14	1	SK-1718-C	DUMMY SIDEPLATE
15	1	SK-2217	SOCKET (LJS ONLY)
16	1	HP-N-4064	SPACER (DIFF POST)

**LOW FRICTION PINION HEAD BEARING TOOLING**

Bill of Material		FTR LOW FRICTION BEARING TOOLING	
Position	Qty	PartNo	PartName
1	1	BEA-410	PINION BEARING ASSEMBLY
2	1	SCR-015	SOCKET CAP SCREW
3	1	SK-2394-A	FTR LF BEARING TOOL
4	1	SK-2394-B	FTR LF BEARING TOOL
5	1	SK-1807	FTR LF BEARING TOOL

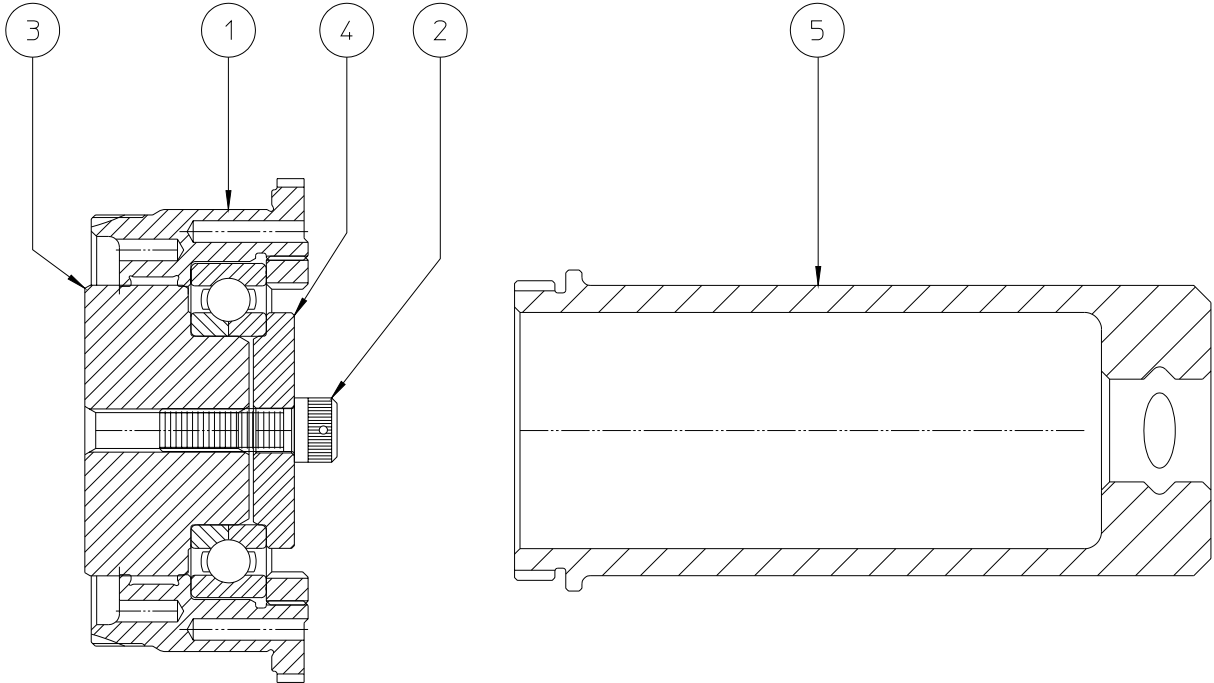

# INSTALLATION DRAWINGS: MAINCASE AND BEARING CARRIER



# FTR MAINCASE (FTR-201)

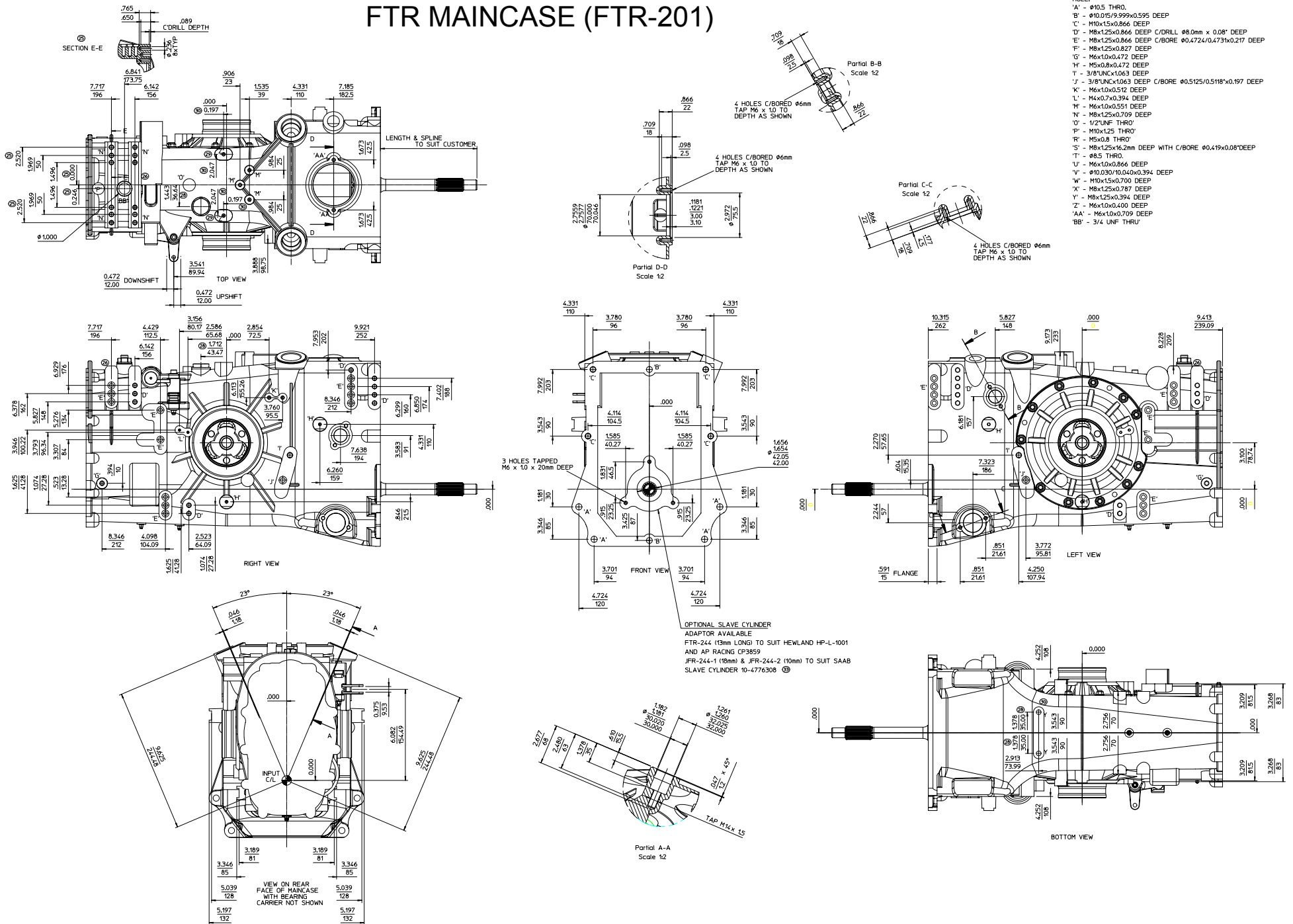



# BEARING CARRIER VARIATIONS

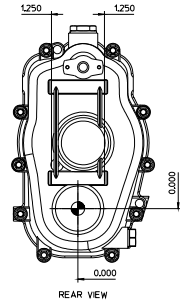
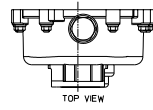

5 SPEED WITHOUT CRASH BOX FLANGE

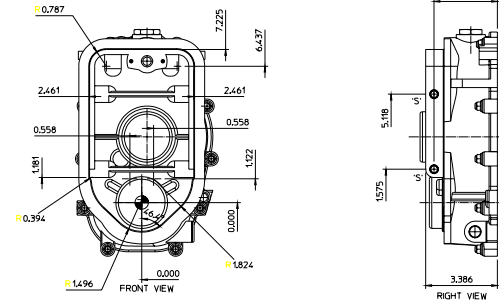
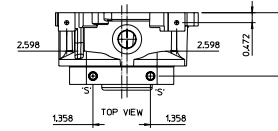

5 SPEED WITH CRASH BOX FLANGE

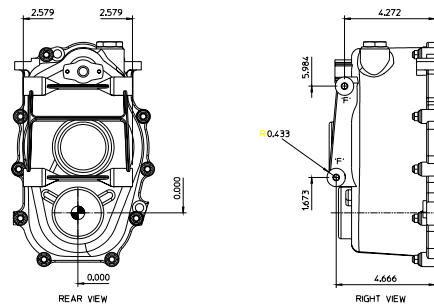
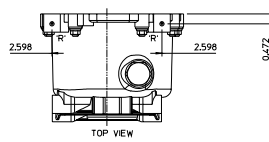

6 SPEED WITHOUT CRASH BOX FLANGE

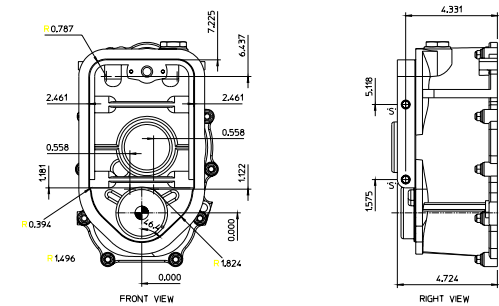
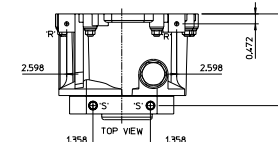

6 SPEED WITH CRASH BOX FLANGE

SEE PREVIOUS SHEETS FOR GENERAL DIMENSIONS OF MAINCASES

**Fig.45**

# OUTPUT FLANGE VARIATIONS

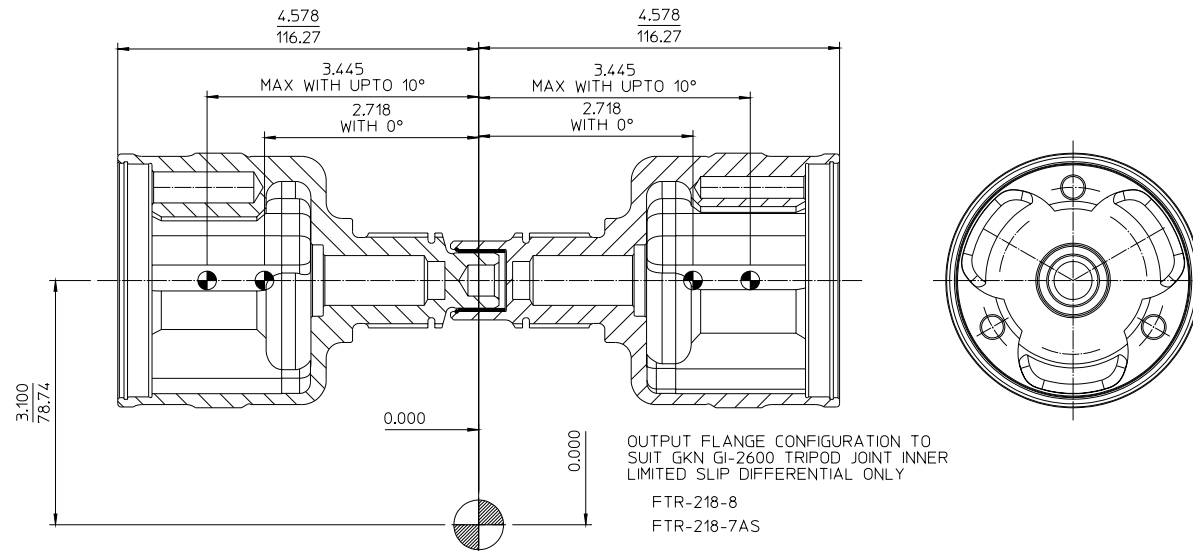
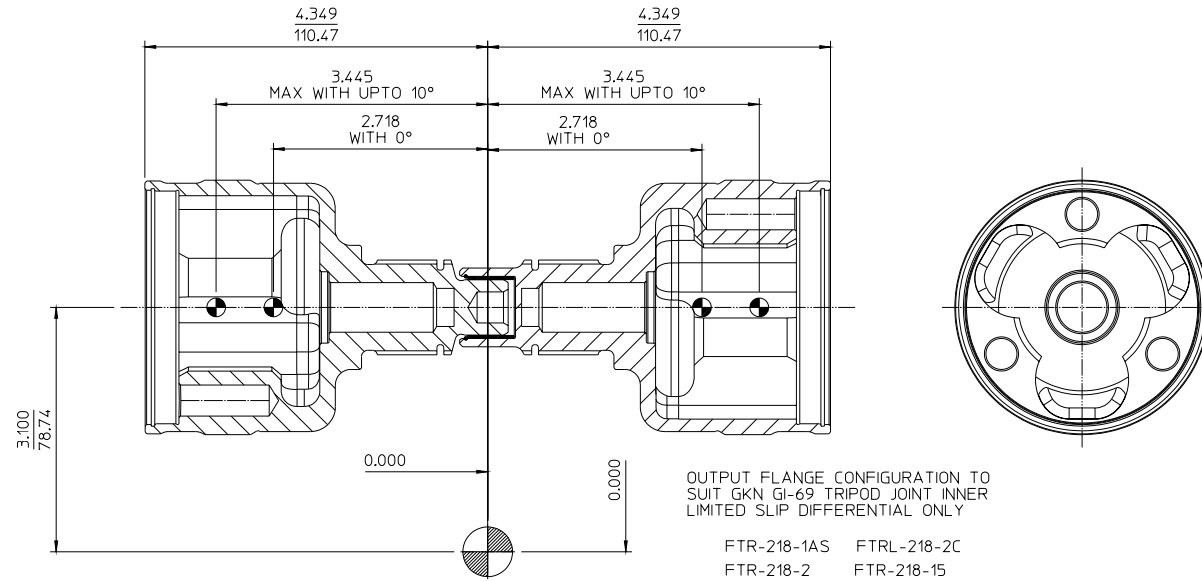

**Fig.46a**

# OUTPUT FLANGE VARIATIONS

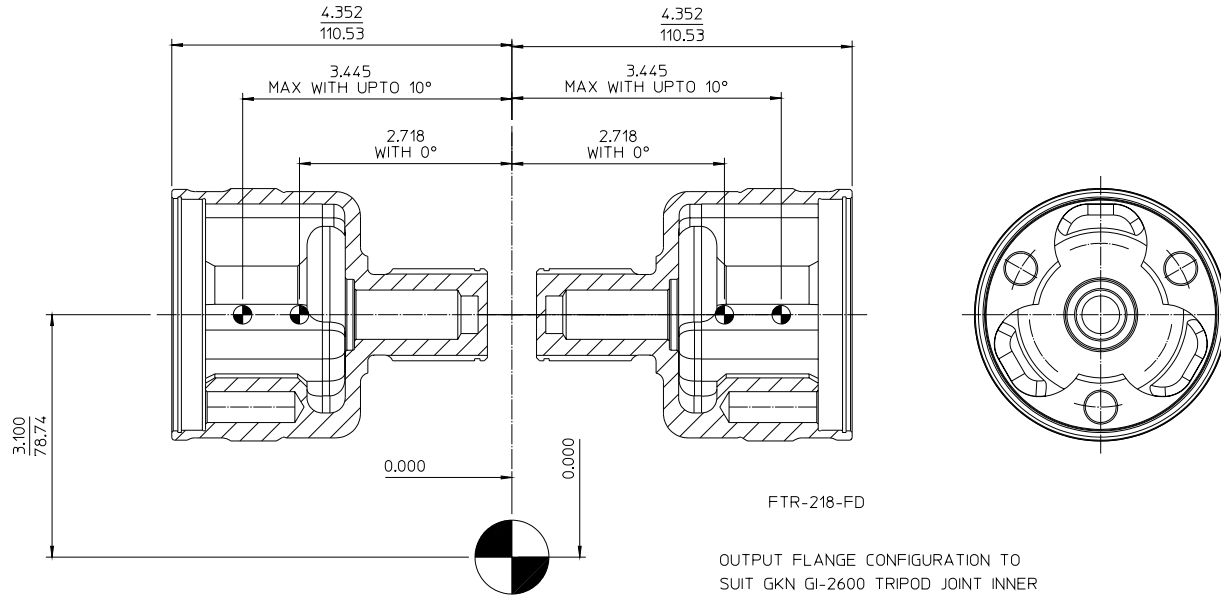

OUTPUT FLANGE CONFIGURATION TO  
SUIT GKN GI-2600 TRIPOD JOINT INNER

**Fig.46b**

LD-212-CP  
CAM & PAWL

LD-212  
POWERFLOW

LJS-212-F  
FREE DIFF

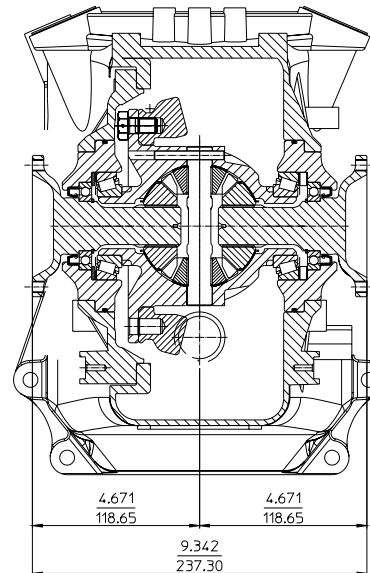
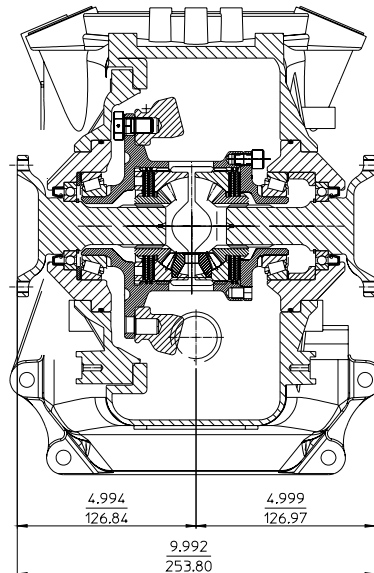
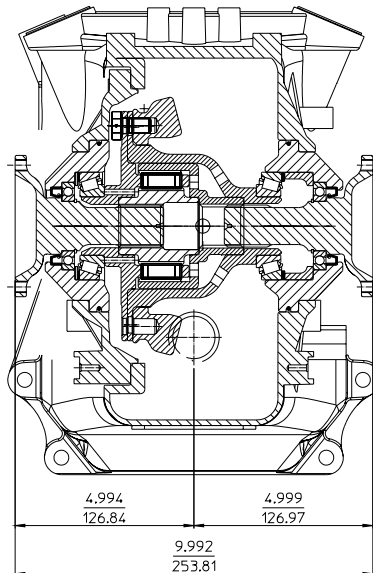

LJS-218 FLANGES

6 HOLES  $\phi 0.3125/0.3131$   
THRO' SPACED AS  
SHOWN ON A 3.1496 PCD  
CHMFR THIS SIDE 0.030 x 45°

6 HOLES DRILL & TAP  
M8 x 1.25 THRO' EQUI-SPACED  
AS SHOWN ON A 3.386 PCD

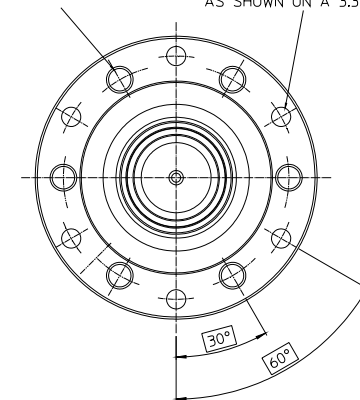

# OUTPUT FLANGE VARIATIONS

LD-212-CP  
CAM & PAWL

LD-212  
POWERFLOW

LJS-212-F  
FREE DIFF

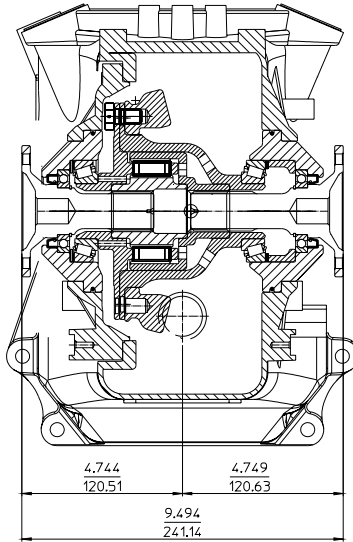

INBOARD BRAKES

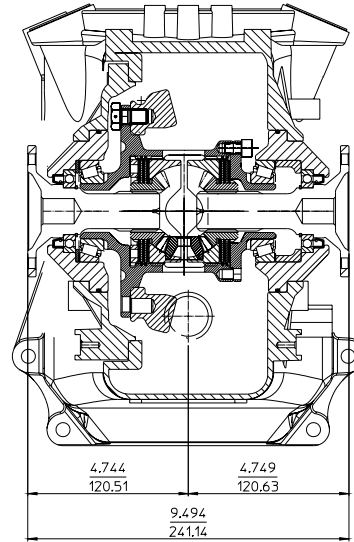

INBOARD BRAKES

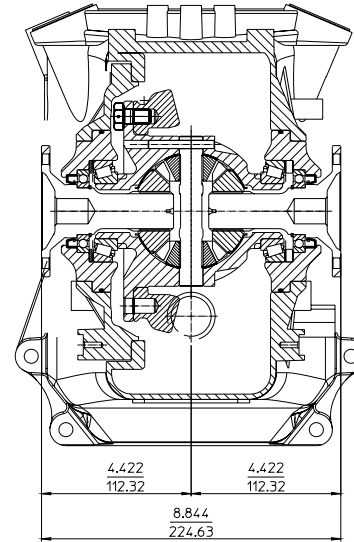

LD-218-LH/RH FLANGES

NOTE:  
FOR FREE DIFFS USE 2 X L/H  
FOR LD 212 POWERFLOW  
AND CAM & PAWL USE 1 X L/H & 1 X R/H

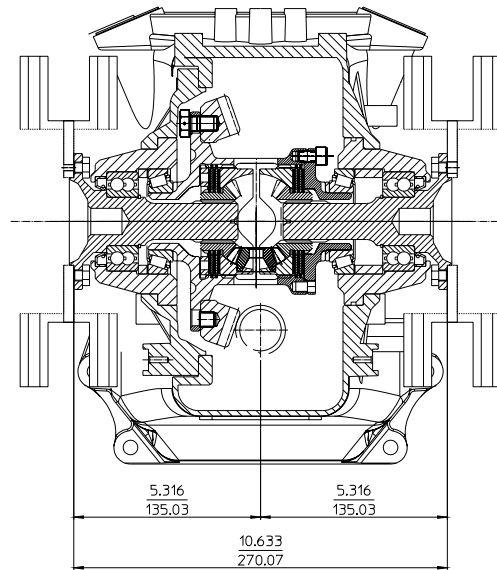
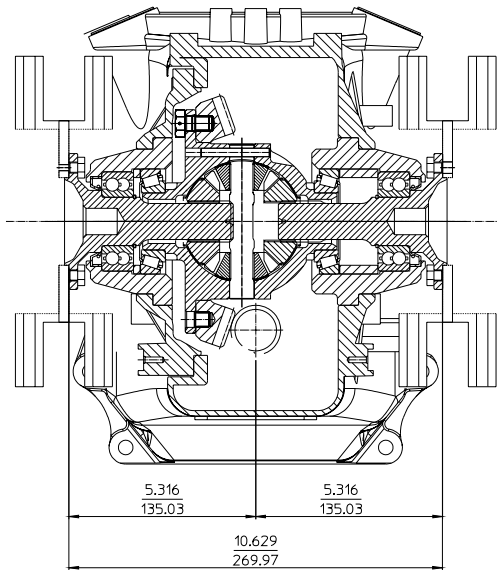
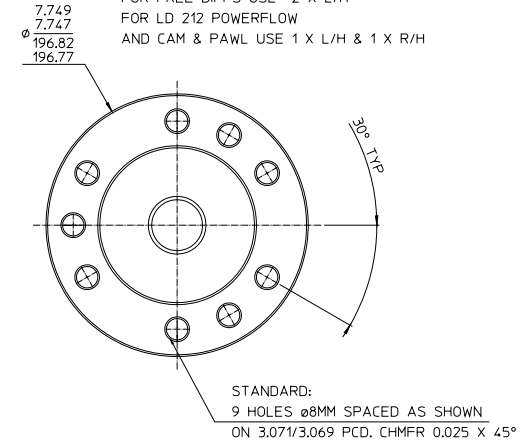

CS-1721

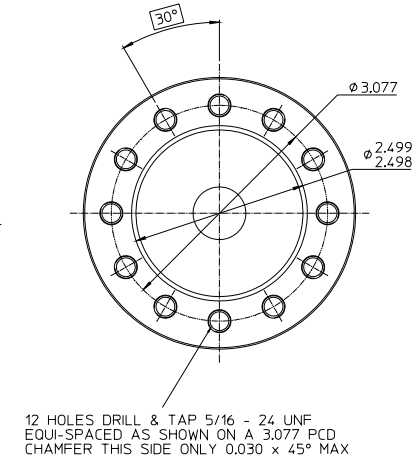

FTRE-218-LAS AND  
FTRE-218-RAS

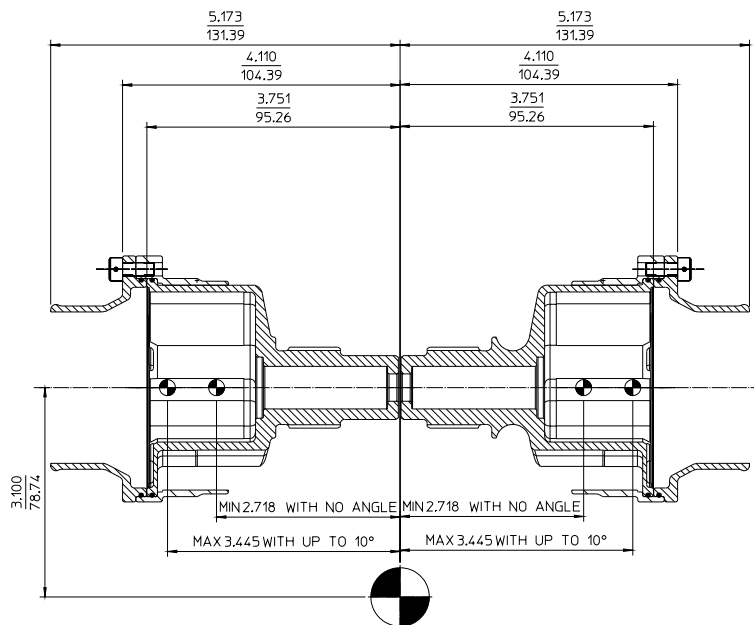

FTRL-218-LAS AND  
FTRL-218-RAS

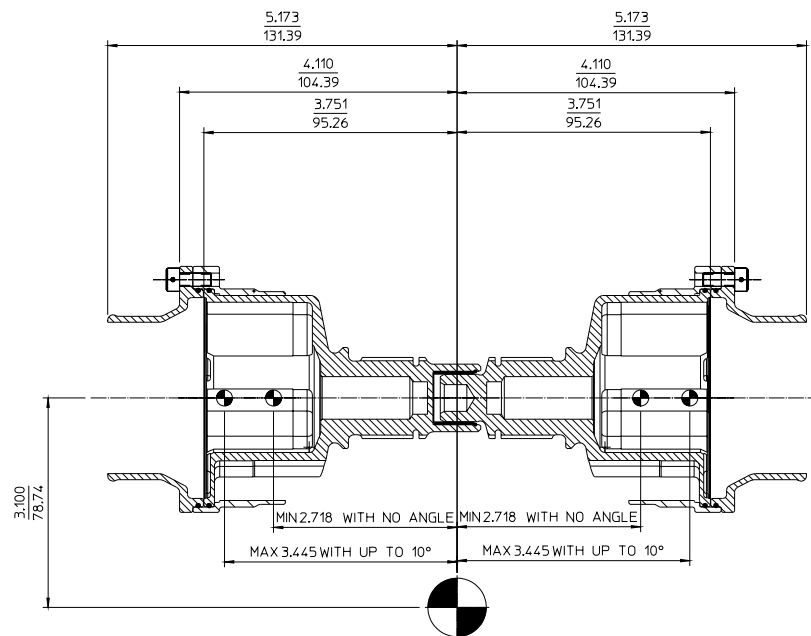

Fig.46d

## Pneumatic Shift Actuator Installation:

A 2 way pneumatic actuator is available for the FTR gearbox, which can be used in conjunction with pneumatic shift systems (such as Hewlands own proven paddle shift system).

The actuator bracket mounts directly onto the boss shown on the FTR maincase allowing the actuator to be mounted here and attached to the existing bell crank.

Position	Part Number	Qty	Description
1	BEA-452	1	ROD END
2	HC-202-10	1	PLAIN NUT
3*	HYD-071	2	JIC -3 FITTING
3*	HYD-072	2	JIC -4 FITTING
4	LD-202-9	2	WASHER
5	NUT-001	1	KAYNUT
6	NUT-004	1	KAYNUT
7	PNU-039	1	ACTUATOR
8	SCR-298	1	HEX HEAD SCREW
9	SCR-358	1	SOCKET HEAD SHOULDER BOLT
10	SGT-244-13	2	SOCKET CAP SCREW
11	SK-2286	1	BRACKET
12	SK-2444-A	1	WASHER
13	WSH-015	1	WASHER
14	WSH-090	1	DOWTY WASHER

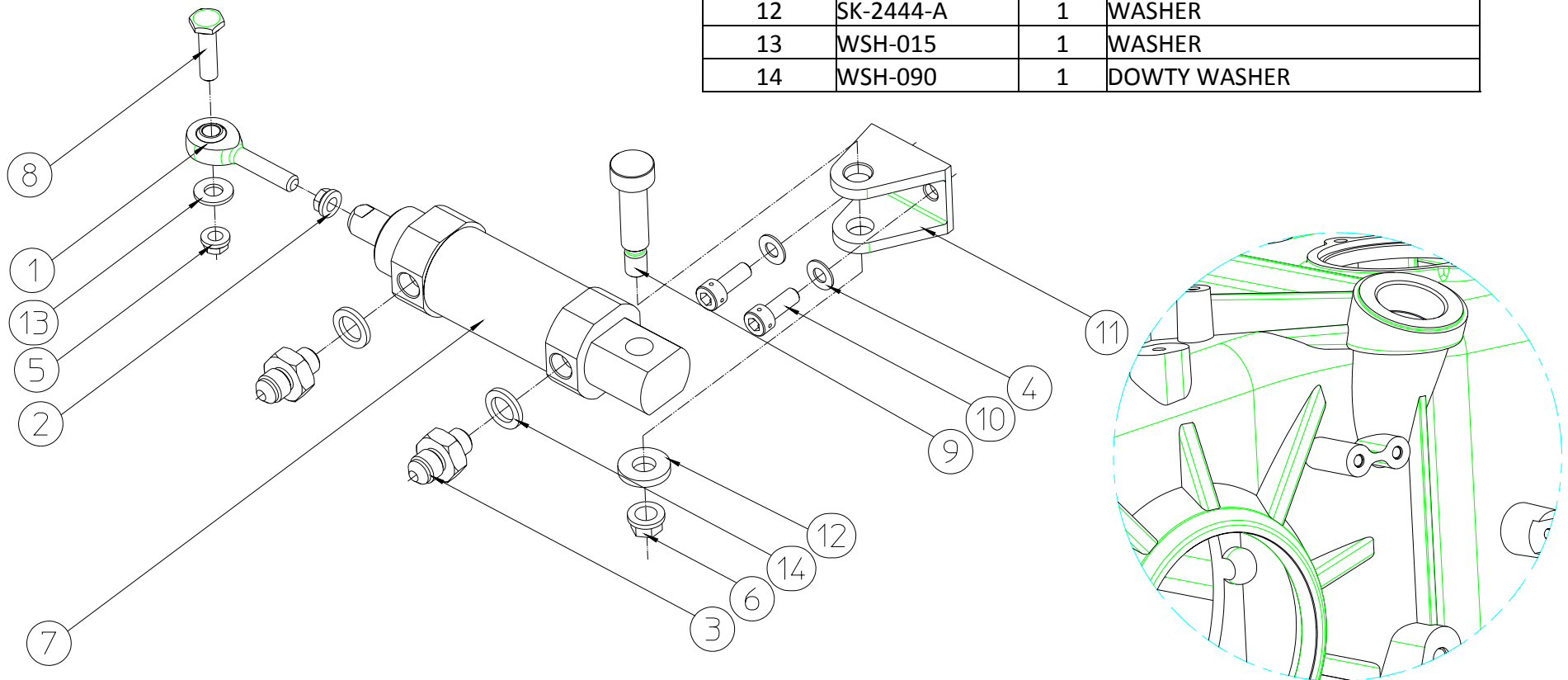



## Customer Memo – FTRL hubbed 2<sup>nd</sup> ratios

2<sup>nd</sup> JUNE 2005

As you may be aware, FTRL ratios are beginning to reach the Hewland stores. Customers should note that the hubbed 2<sup>nd</sup> gear ratios (such as FTRL-15:26-HUB) require an additional spacer to be fitted on to the layshaft. This spacer does not come as part of the ratio sets and should therefore be purchased separately. It is available from the Hewland stores, part number FTRL-235-1A.

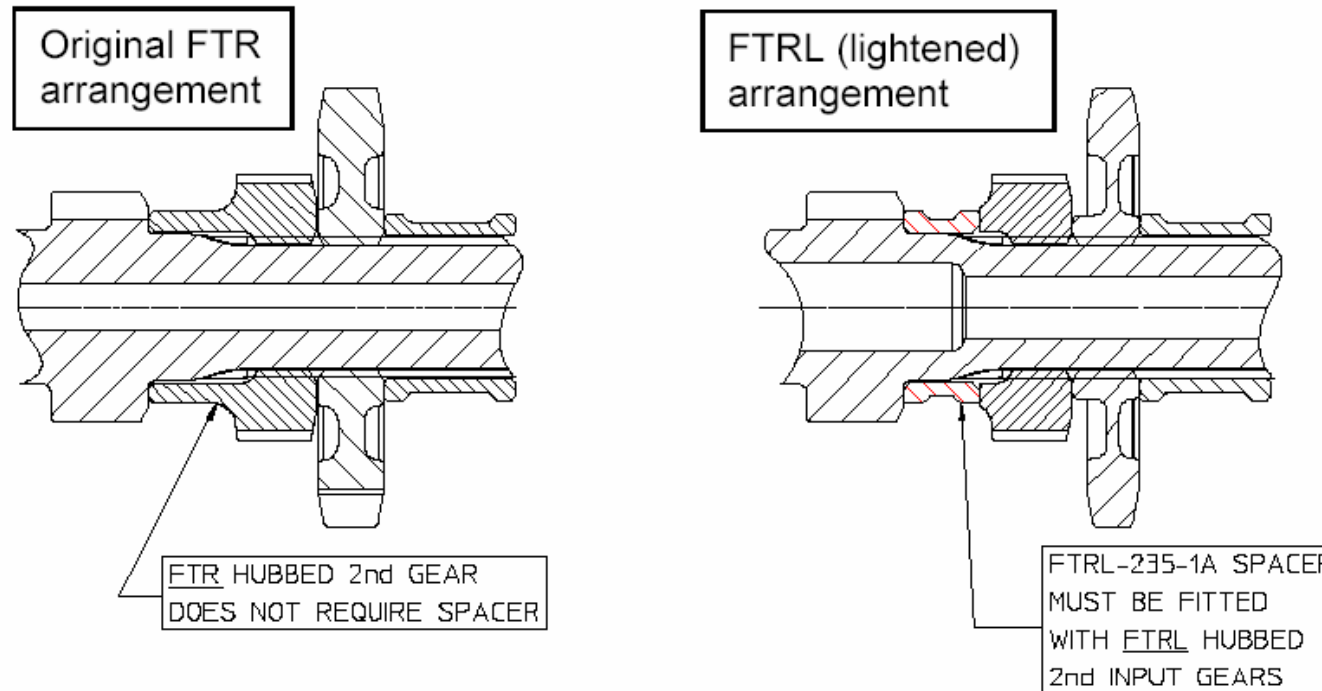

James Batchelor  
Design Engineer

## Technical Bulletins

### FTC DIFFERENTIAL - LOCKING PERCENTAGE RATING.

Below is a formula for rating different ramp angles in terms of percentage of the achievable lock.

$$\begin{aligned} & \text{Crownwheel Torque} * \{.378 + [.415 / \text{Tangent}(\text{Ramp} \angle)]\} * \mu * \text{NoOfPlateSurfacesUsed} \\ & = \text{TorqueTransferableBetweenWheels} \end{aligned}$$

The above formula gives a good approximation of the locking force as a percentage of a diff that has been set up with a full complement of working plate surfaces, and a set of 30 degree ramps. It can be seen from the above formula that 34 percent of the locking action is not provided by the ramps. This locking component is due to the reaction forces of the side bevel gears.

Put another way, the locking torque can be approximated using this formula :

$$\left[ \frac{38}{\text{Tangent}(\text{Ramp} \angle)} + 34 \right] * \frac{\text{NoOfPlateSurfacesUsed}}{\text{Max PossibleNoOfWorkingSurfaces}} = \text{PercentageLock}$$

Where  $\mu$  is the friction coefficient between the plates.  $\mu=0.1$  can be used for steel plates.

## **FTR Technical Bulletin No. 01A**

### *AMENDMENT TO BULLETIN No. 01*

### **Bearing Carrier (FTR-202)**

*This bulletin replaces FTR Technical Bulletin No. 1. Note that the retaining washer has been reduced in diameter to 23mm. This is to ensure that the washer cannot interfere with spacer LD5-229-4. The new WSH-051 will be available from Hewland Engineering.*

**Existing WSH-051 must not be fitted unless they have been modified in diameter to 23mm.**

It has come to our attention that there is a possibility of the bearing outer track (BEA-002) moving out of position during use.

To overcome this problem Hewland Engineering will be adding a 5mm tapped and countersunk hole to the bearing carrier for a bearing retaining screw & washer to be fitted.

All our existing and future stock will feature this tapped hole. It is recommended that all FTR-202 Bearing Carriers are modified as shown below and fitted with an M5 x 10mm long Countersunk screw & washer (Hewland Parts: SCR-023 & WSH-051).

The tapped hole will break out of the casting and therefore hydraulic sealant must be used when fitting the screw. This will not be the case on future castings which will be modified for this reason.

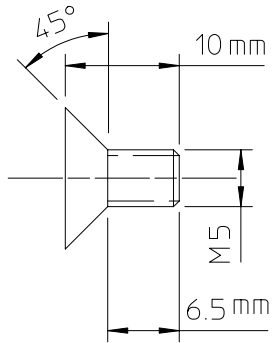
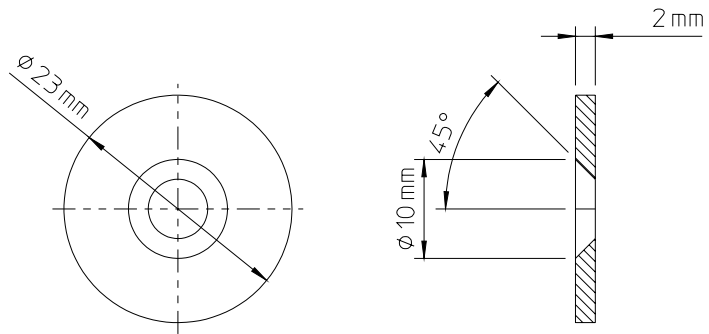

James Batchelor  
Design Engineer

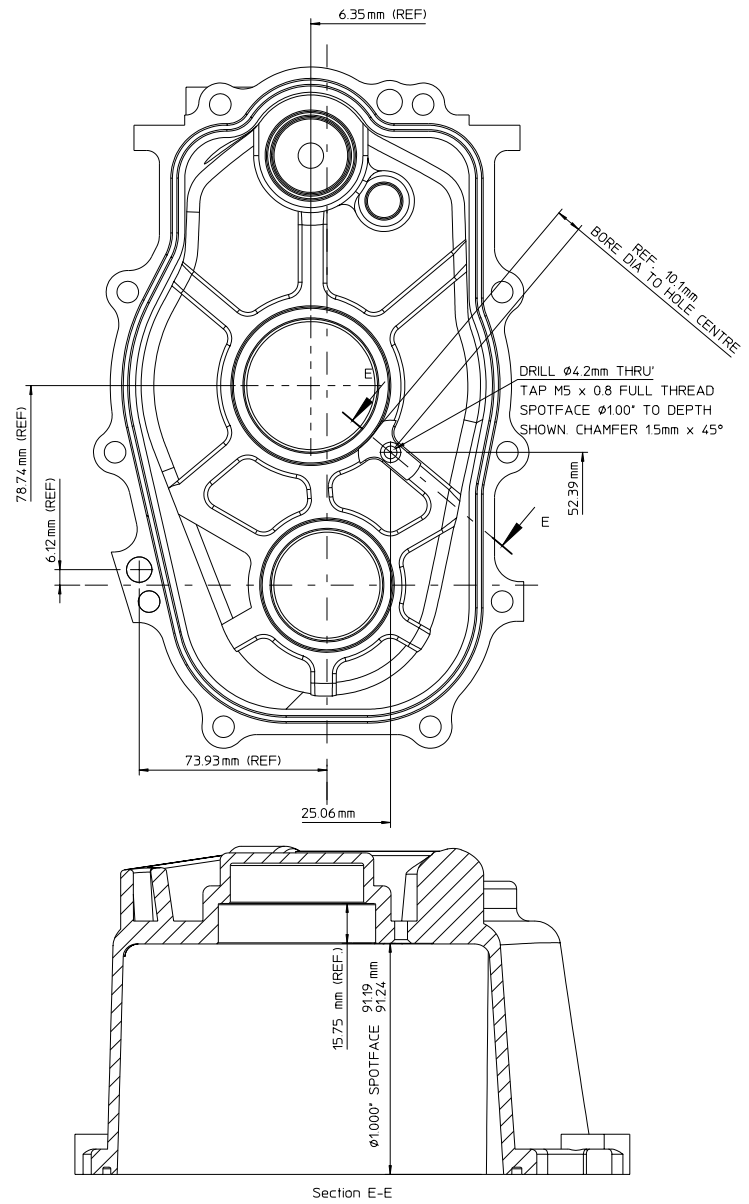

Fig.48

FTR Technical Bulletin No. 02

Bearing Anti-rotation (FTR-201 & FTR-202)

It has come to our attention that there is a possibility of the bearing/outer tracks (BEA-002 & BEA-159) rotating during use.

To overcome this problem Hewland Engineering will be adding 2.5mm DIA. x 3.5mm deep dowel holes to the bearing bore faces on the Maincase and Bearing carrier castings, to allow an anti-rotation dowel to be fitted.

All our existing and future stock will feature these dowel holes. Its is recommended that all FTR-201 Maincases and FTR-202 Bearing Carriers are modified (as shown below) so that a 2.5mm DIA. X 5mm long dowel (Hewland Part: DOW-018) can be fitted.

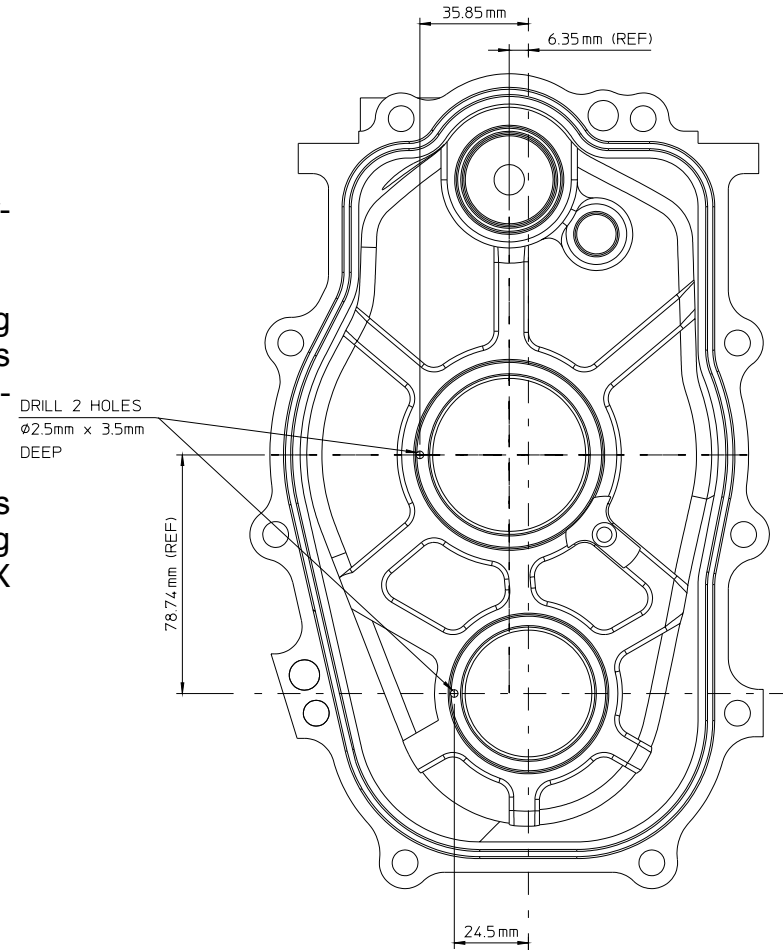

FTR-202 Bearing Carrier

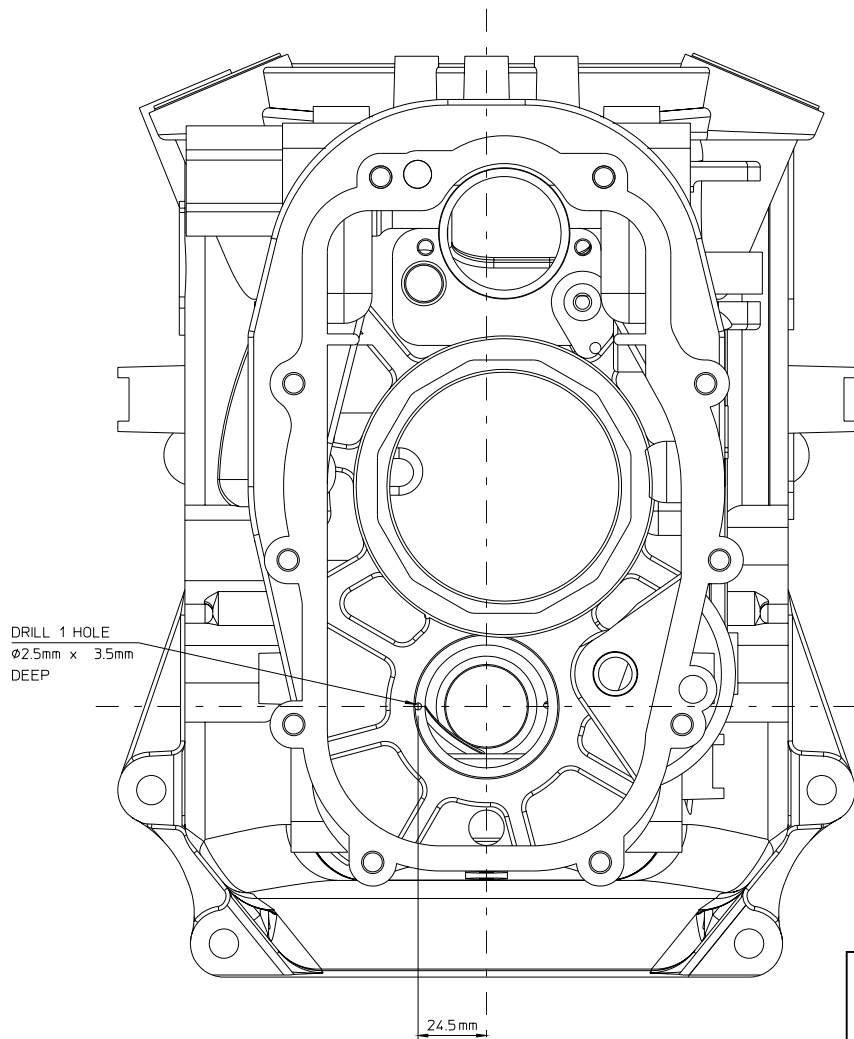

FTR-201 Maincase

James Batchelor  
(Design Engineer)

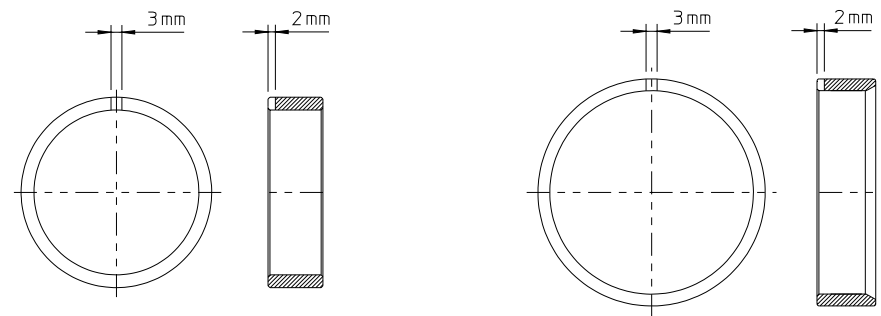
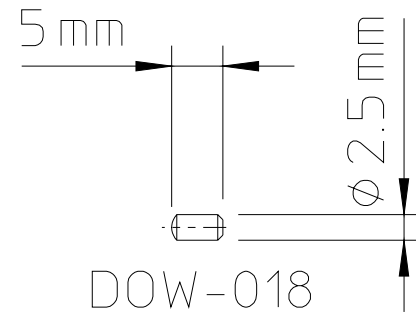

BEA-159 OUTER TRACK

BEA-002 OUTER TRACK

The bearings (BEA-159 & BEA-002) will also require modification if the anti-rotation dowels are to be fitted. The outer tracks of the bearings will need a 3mm wide x 2mm deep slot machined on the seating face (as shown below).

14/02/03

## **FTR Technical Bulletin No. 003**

### **Re-pinning of selector barrel (FTR-260)**

On a few occasions during the 2002 season, the pins within the selector barrel failed. The specification of the pin was immediately increased and as an act of good faith, for the past year, all barrels returned to the factory have been re-pinned FOC.

While this service will continue to be available it will, with effect from this bulletin, cease be FOC.

A charge of £50.00 will be made for each barrel returned to Hewland Engineering for re-pinning. Alternatively replacement pins (part # DOW-033) are available through your normal Hewland supplier.

**FTR Technical Bulletin No. 004**

**Barrel pin (DOW-033)**

To date there are some 300 FTR type gearboxes in service.

Of the initial batch of some 20 gearboxes a quantity of the selector barrels were fitted with sub standard pins (see tech bulletin # FTR 03). This fault was quickly recognised and dealt with. Since that time there have been few instances of pin failure. However, during the course of remanufacture, for our stock, we have taken the precaution of strengthening the pin. The new stronger pins will supersede the earlier version for all new supply, and are recognisable from the earlier version by an identification dimple in one end.

It is not our recommendation that all original pins be changed, but should you so wish, the new pins are available under the same part number through your normal Hewland supplier.

As all existing stocks have expired, with effect from this bulletin, all DOW-033 obtained from Hewland Engineering will be to the new specification.

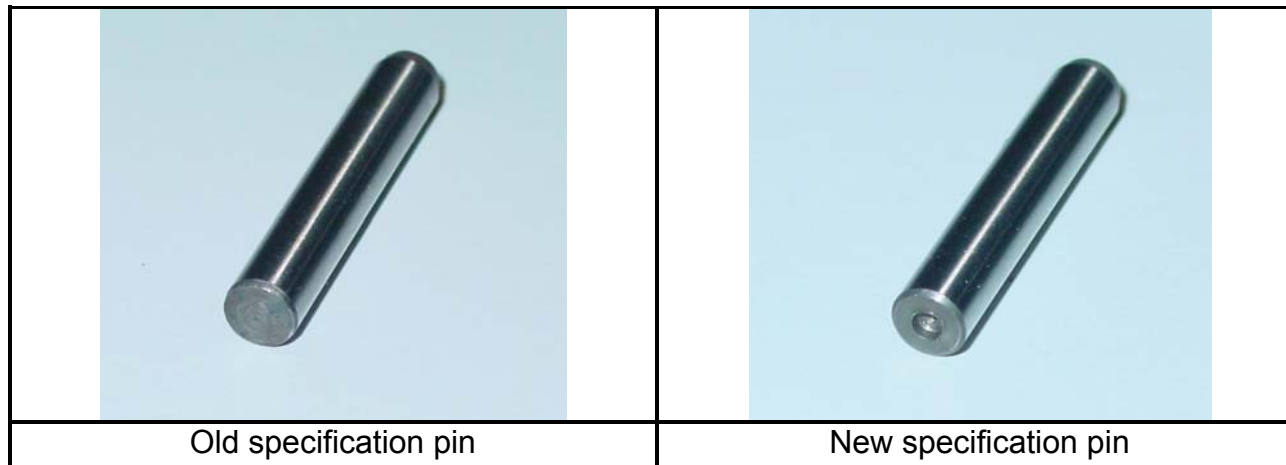



**Technical Bulletin FTR 005**  
**Replacing selector barrel pins.**

Using an end cutter, grind through the old pin for approx 1/3 of its thickness

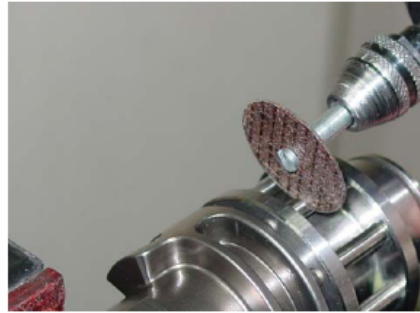

The position of the cut should be about 4mm from the inner face.

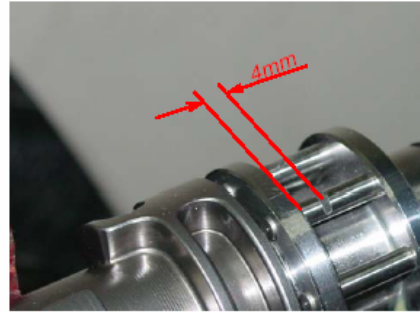

Using a small cold chisell (as this tends to hold the direction of impact) drive the pin out of the barrel.



Stop when the undercut is level with the inner face. Do not drive the undercut into the hole as this will broach the bore.



A sharp tap to the side of the pin will break off the lower portion.



Use a punch with a diameter smaller than the pins to drive the remaining part of the pin back through the hole and free of the barrel.



All 8 pins should be replaced at the same time.  
The new pins (see Technical Bulletin FTR04) should be fitted with the dimple to the outside and flush with the outer face.



28<sup>th</sup> July 2003

## FTR Technical Bulletin No. 006

### Input/Clutch Shaft Retention Circlip

The FTR gearbox, when assembled, is designed to retain the input shaft (FTR-239-#) without a circlip being used. The clip was introduced to ensure that whilst carrying out a ratio change i.e. removing the rear cover of the gearbox, the shaft would remain in position.

In practice it has become apparent that the machined circlip groove is of a design, that when the shaft is installed, with the circlip fitted, it allows the clip to drop out of position. This then makes it impossible to remove the shaft with the gearbox in position.

The need to retain the shaft during ratio changes has not been an issue, and as the groove is potentially a stress raiser that could promote shaft failure, Hewland Engineering Ltd. have removed the groove from the Input/Clutch Shaft drawing.

All Input/Clutch Shafts supplied in future will not have this groove.



19th July 2004

## FTR Technical Bulletin No. 007

### PINION THREAD STRIPPING

Hewland Engineering has received several notifications of failed FTR pinion shaft threads.

These failures are, it appears, limited to Formula 3 users, (regular ratio changes).

It is recommended by Hewland Eng. the pinion nut (FTR-230) is replaced at regular intervals, it is suggested that 10 torque cycles would be the limit.

It is also recommended that the tightening torque of the nut is reduced from the current setting of 135 Nm (100lbs.ft.) to 100 Nm. ( 75 lbs.ft.)

On replacement of a C.W.P. the pinion nut should be replaced as a matter of course.

It has also been evident that impact guns have been used to tighten pinion nuts, this is unacceptable

Note:

The above recommendations apply to all users of the FTR gearbox not solely F3

Hewland Eng. is also developing a more compliant thread for future manufacture

25th January 2005



**SQUARE FACE ON  
END OF SPLINES**

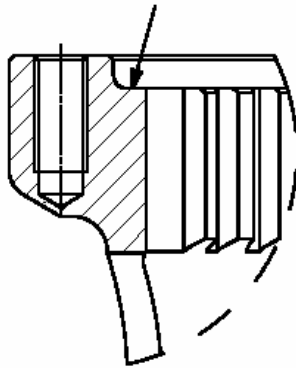

**CHAMFERED FACE  
ON END OF SPLINES**

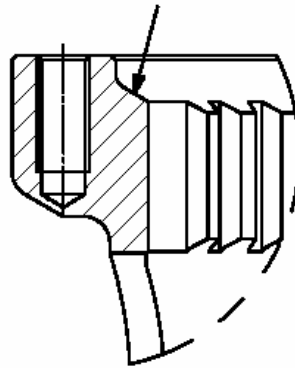

The photographs and part sections above are of the two versions of the FTR differential case, part number FTR-213.

The version shown on the left is to the latest specification with a "square" face on the end of the internal friction plate drive splines. This enables the fitting of sufficient plates to give a maximum of 12 friction faces.

The version shown on the right is to the previous specification with a large chamfered face on the end of the friction plate drive splines. This only enables the fitting of sufficient plates to give a maximum of 8 friction faces.

Below is a section through the differential, showing the latest design of diff case, set up with the friction plates positioned in the standard "Formula BMW" configuration to give 8 working faces.

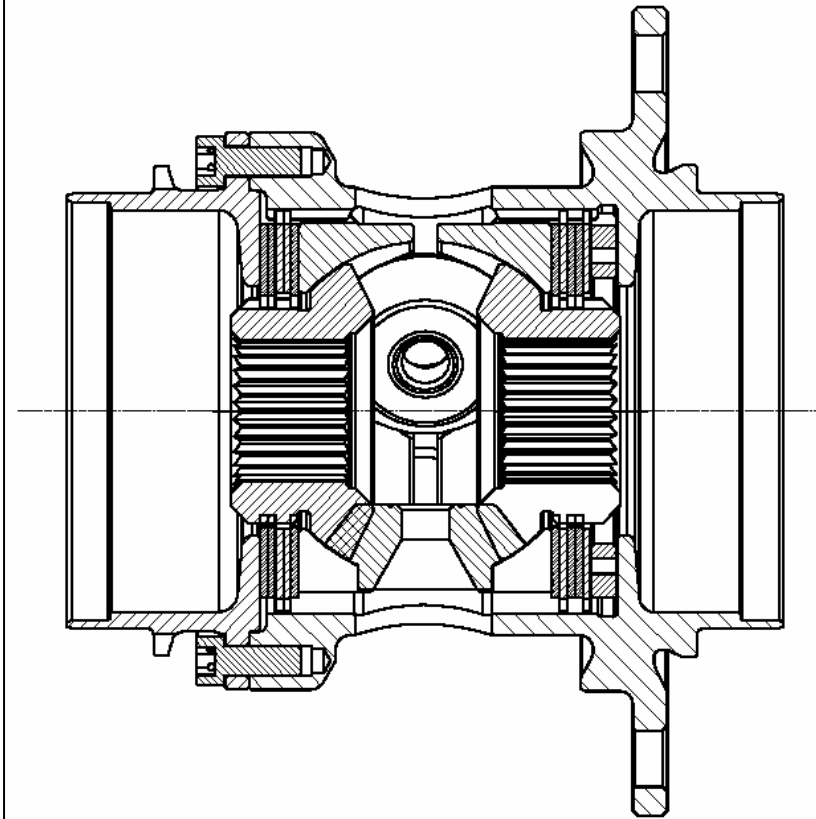

3<sup>rd</sup> February 2005

FTR Technical Bulletin No. 09  
**FTRL Gears**

As you may know, a range of lightweight FTR gearbox parts is in production at Hewland Engineering. We have also carried out a review of the FTR gear ratio situation, with particular respect to the Formula Three market.

It has been decided that Hewland will imminently commence production of a range of lightweight FTR gear ratios known as `FTRL` which are aimed at offering the fullest practical weight saving for the Formula Three market.

These gears will not be `the ultimate` lightweight components that Hewland *could* produce, but they will afford a **0.9kg** weight saving over a standard FTR layshaft and full gear set, whilst still maintaining long life. Perhaps more relevant is that the weight saving over a prolific *non-Hewland* full gear set that we have studied will be **0.63kg**. In fact certain of these `pirate` gears are actually *heavier* than our *standard* FTR, despite narrower tooth face width!

The FTRL gears will have narrower face widths than the pirate gears, so the competitive advantage is enhanced due to lower inertia, as `highest diameter` mass is less.

The superior tooth form and superior heat treatment found in genuine Hewland FTR gears will still be present in our new lightweight range. This will afford both advantageous weight and superior transmission efficiency over other suppliers.

The FTRL gear cluster will come with a new layshaft, for weight reasons. However all splines and fits are the same, which will allow the mixing and matching of FTR and FTRL gears if need be. This should be very cost effective as a way of phasing out FTR gears, perhaps during testing.

The main message is this: *We advise that you do not stock up on inferior competitors gear ratios before the FTRL range is available, as this will cause you competitive disadvantage. Lighter and more efficient gears are coming soon!*

William Hewland  
Managing Director

4<sup>th</sup> February 2005

## FTR Technical Bulletin No. 10 FTR Lightened Clutchshafts

As you may know, a range of lightweight FTR gearbox parts is in production at Hewland Engineering. We have also decided to offer lightened clutchshafts – specifically for the Formula Three market.

We are now able to offer the following lightened clutchshafts:-

Hewland Part N°.	Engine/Chassis	Approx. Weight Saving (Kg)
FTR-239-35	Mercedes/Dallara*	0.385
FTR-239-36	Mugen/Dallara*	0.37
FTR-239-37	Nissan/Dallara*	0.36
FTR-239-38	Opel/Dallara*	0.39
FTR-239-39	Toyota/Dallara*	0.365

\* 2005 spec

Our research shows that some FTR clutchshafts could be re-designed to save in excess of **0.5Kg** – any customers who are interested in purchasing lightened clutchshafts for other FTR applications should contact a member of the Hewland Engineering sales team ([sales@hewland.com](mailto:sales@hewland.com)) to discuss their specific requirements.

James Batchelor  
Design Engineer

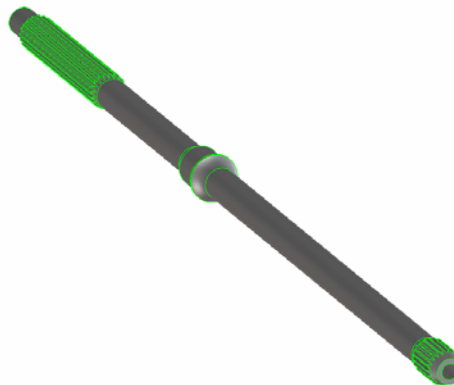

## FTR Technical Bulletin No. 011

### FTR/FTRL 12:34 Pinionshaft – Locking Nut & Ring

Hewland Engineering has recently been made aware of some thread failures on FTR pinionshafts. The occurrence of these failures was limited to the 12:34 ratio (used mainly in Formula 3 applications). Two steps have been taken by Hewland Engineering to ensure future failures are avoided, these are:-

1. All FTR pinionshafts will now feature rolled threads.
2. The 'problematic' pinionshaft (12:34) will now feature a longer thread.

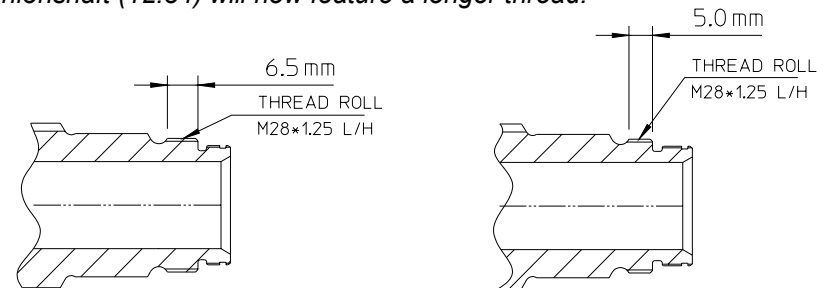

**Fig. 1** Longer thread on 12:34 pinionshafts (left)

Customers who run 12:34 FTR pinionshafts need to be aware that the new 'lengthened thread' parts (which will be phased in over the next few months) require a different locking nut and locking ring. The new lock nut (to replace FTR-230) is **FTR-230-A** and the locking ring is **FTR-230-B** (which will replace HP-M-4026). For final drive ratios other than 12:34 the nut & ring remain unchanged. These new parts will be available from Hewland stores shortly.

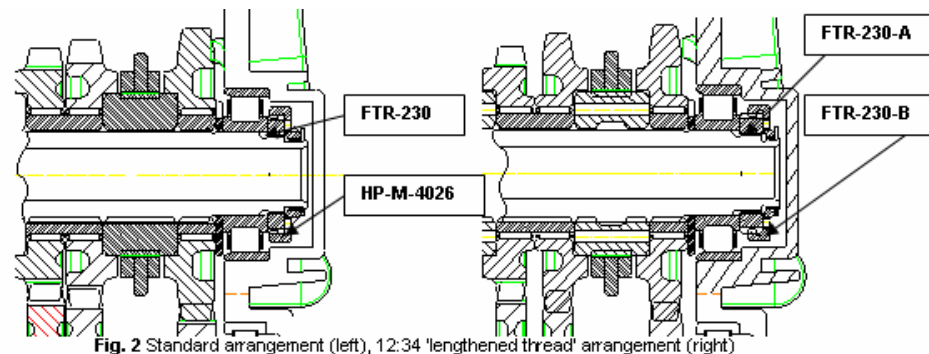

**Fig. 2** Standard arrangement (left), 12:34 'lengthened thread' arrangement (right)

The lightweight FTRL pinionshaft is also affected, as a 12:34 ratio will also feature the longer thread and will therefore require the new locking nut & ring as mentioned above.

James Batchelor  
(Design Engineer)

**FTR Technical Bulletin No.013**

**POSITION OF GEAR INDICATOR POTENTIOMETER**

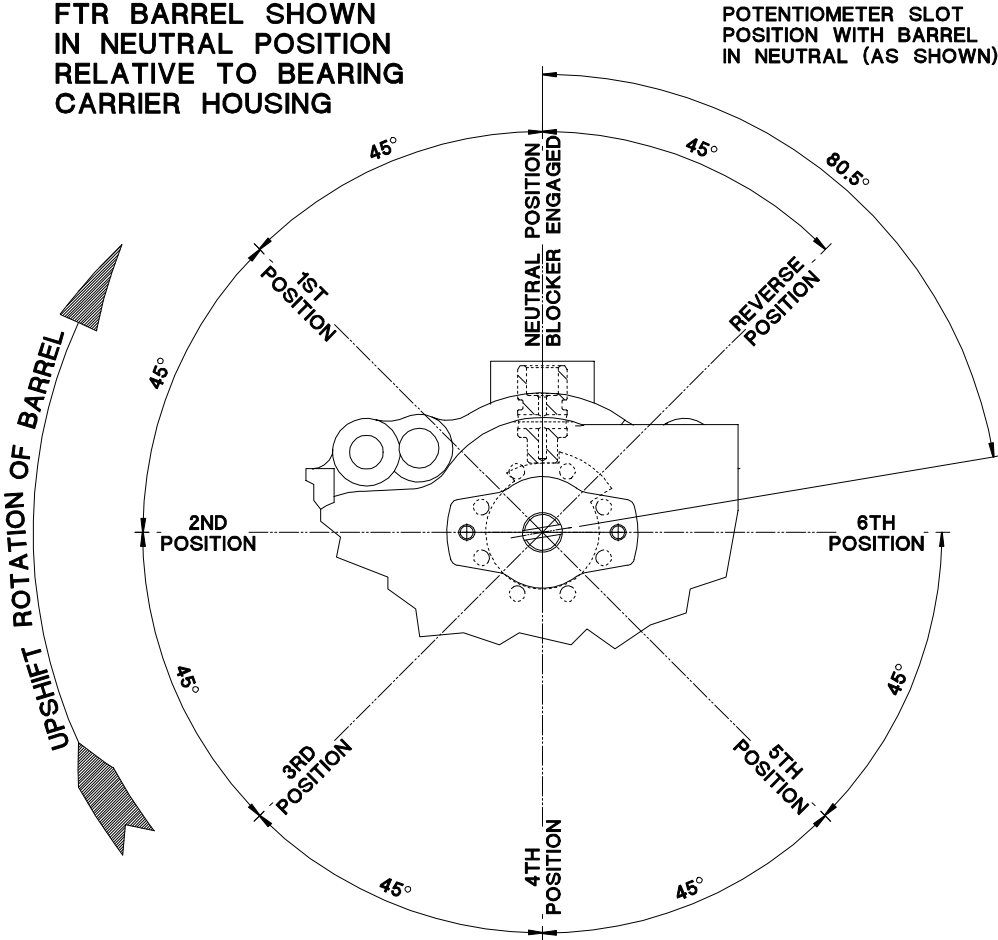

**Fig.52**



# FTR Technical Bulletin No. FTR-014

It has come to our attention that on some EGT gearboxes the reverse idler screw (SCR-117) has come loose, even though having been loctited on assembly. This is the same screw and reverse idler design used in the FTR. It is to be noted that no incidents of this screw coming loose on the FTR has been reported to Hewland. To avoid the possibility of it coming loose we have modified the screw to include four holes to facilitate the use of lockwire and have also modified the maincase FTR-201 as well with a hole to pass it through.

We recommend that this modification be done to all gearboxes that you have. Below are the details of the modifications.

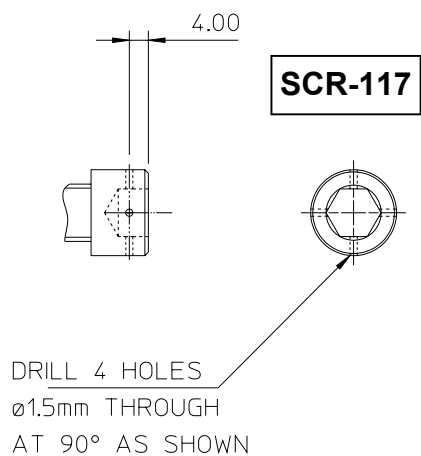

**FTR-201 MAINCASE**

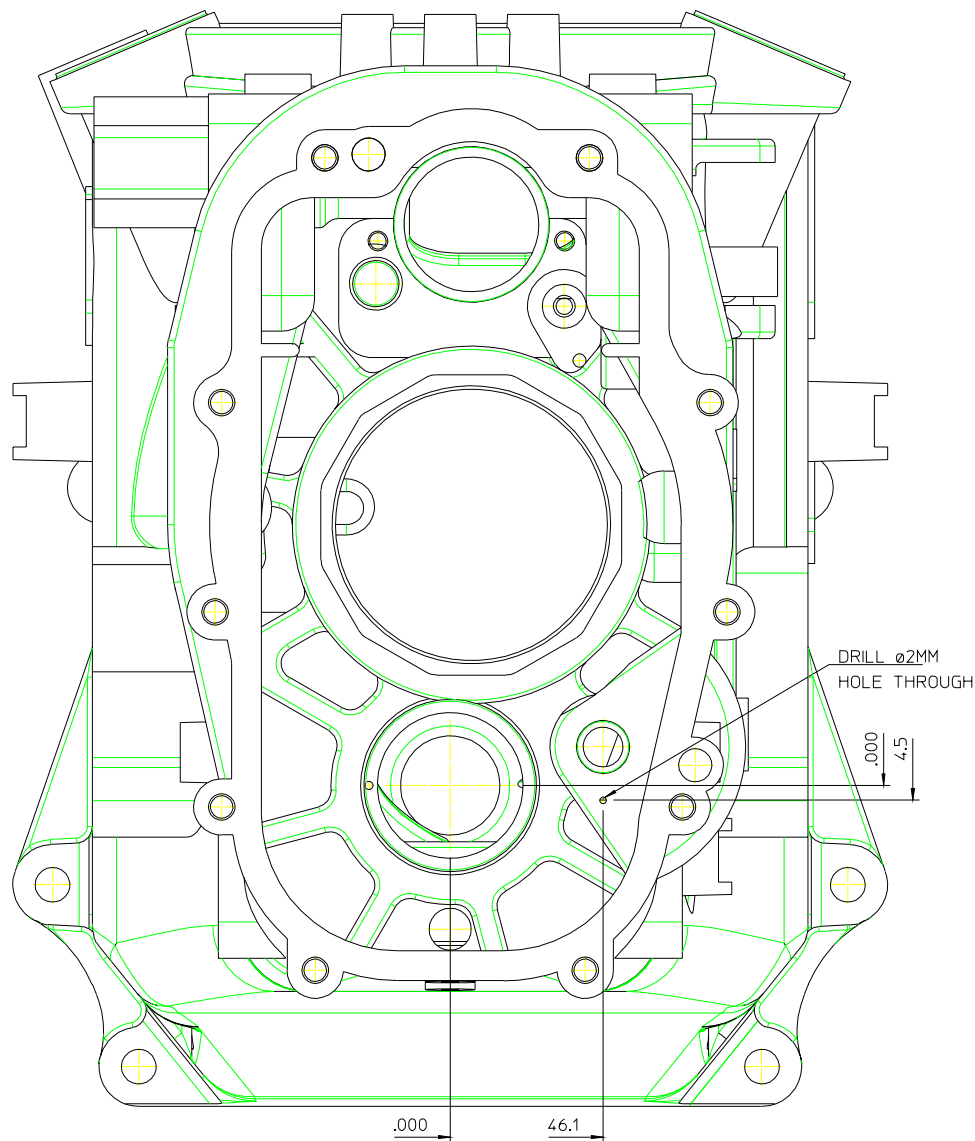

**Fig.53**

## **FTR Technical Bulletin No. FTR-015**

### Pinion Bearing Nut Revision

Some customers have reported instances of the pinion bearing nut FGA-222-1A coming loose, during gearbox operation. In an effort to alleviate the loosening of the locknut, the design has been enhanced, increasing its radial thickness, length, and the material specification.

This modification has also enabled us to incorporate the washer HC8-222-2A into the locknut, so making the washer redundant.

The latest design of locknut has been re-numbered as NUT-031, and the relevant tightening torque has been increased to 150 lbs.ft (205 Nm).

As on the earlier locknut, the outside face is grooved, so leaving a thin section which **must** be peened over in two positions, into the corresponding grooves machined into the bearings threaded diameter.

The locknut must also be fitted using loctite 2701 thread lock.

If for any reason the locknut is fully fitted (i.e. peened over), and subsequently removed, we would recommend that a new locknut be fitted.

N.B. These changes do not apply to Formula BMW applications.

## General Technical Bulletin No. GEN-040

### HCC AND FTC SIDE AND PLANET GEARS

Hewland Engineering has produced various designations of FTC and HCC planet and side bevel gears.

For clarity the latest specification gears are:

HCC-213-5AF and FTC-213-5AF

These gears should not be run with any other designation gears

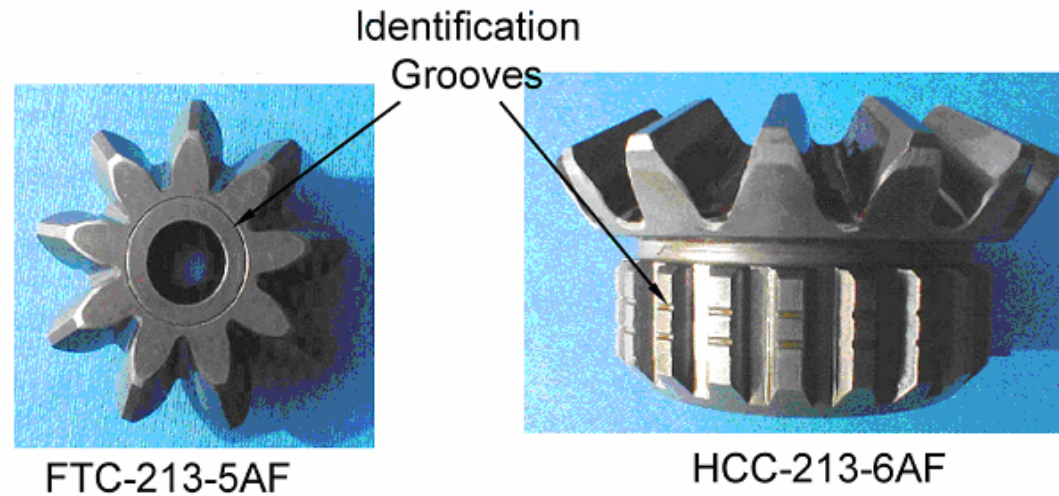

Fig.54

## GENERAL K-NUT TIGHTENING TORQUES

### RECOMMENDED TIGHTENING TORQUES FOR METRIC COARSE SERIES K-NUTS

THREAD	FITTING TO EN16T STUDS		
	(Nm)	(lbs.ins)	(lbs.ft)
M5	8.4	75	6.2
M6	12.7	112	9.3
M8	27.0	239	19.9
M10 x 1.50	40.0	354	29.5
M10 x 1.25	50.0	443	36.9

### RECOMMENDED TIGHTENING TORQUES FOR UNIFIED COARSE SERIES K-NUTS

THREAD	FITTING TO EN16T STUDS		
	(Nm)	(lbs.ins)	(lbs.ft)
1/4	13.0	115	9.6
5/16	26.0	230	19.2
3/8	43.5	385	32.1
7/16	64.9	575	47.9

## Manual Modification History (Started 4th March 2009)

Date	Modification
04/03/09	Detail view added to page 21, modification history page added
23/03/09	Part numbers colour change page 29, omitted washer added page 23
11/05/09	FTR-212-ADJ graph removed tooling added removed from page 56
24/06/09	Installation Drawing updated to include slave cylinder note
10/09/09	Corrections to output flange details for LJS-218
13/10/09	LJS Specific tooling added to pages 64 and 65, LD Powerflow diff ancillaries corrected
14/10/09	Gaitor Assembly added to page 65
16/10/09	Lightweight flanges added Manual anomalies sorted
03/12/09	General technical bulletin 040 added
11/12/09	Cam and Pawl diff added, Installation drawing updated, Low friction bearings added
19/01/10	Output flanges clarified for LJS differentials
27/01/10	Installation for flanges updated for clarity
23/02/10	Obsolete added to FTRE pages
25/02/10	Low friction bearing tooling page added
16/03/10	Gear order added to page 14 and parts lists drawings
22/03/10	Parts added to parts list on adjustable diff page
26/03/10	Installation drawings corrected
27/04/10	Page 46, item 52 part number corrected.
26/07/10	page 60 parts list corrected, page 58 title changed
16/08/10	Page 49 FTRS parts list updated
24/08/10	Pages 69 & 70 Diff post spacer HP-N-4064 added, spacers page 61 corrected
25/08/10	Differential BOM corrected on FTR-212 and FTR-212-ADJ
23/11/10	Part Number requirement for LD flanges on page 78 corrected
26/01/11	Page 80 - pneumatic actuator information added
02/09/11	Page 46 Item 87 corrected